

Please retain as has important information for future use



= Furniture Solutions =

ASSEMBLY INSTRUCTION

KIRRA

ITEM CODE :14KIR482

Imported by Furniture Solutions (Aust) Pty Ltd

10-16 Daisy St, Revesby NSW, 2212, Australia

www.furnitureolutions.com.au

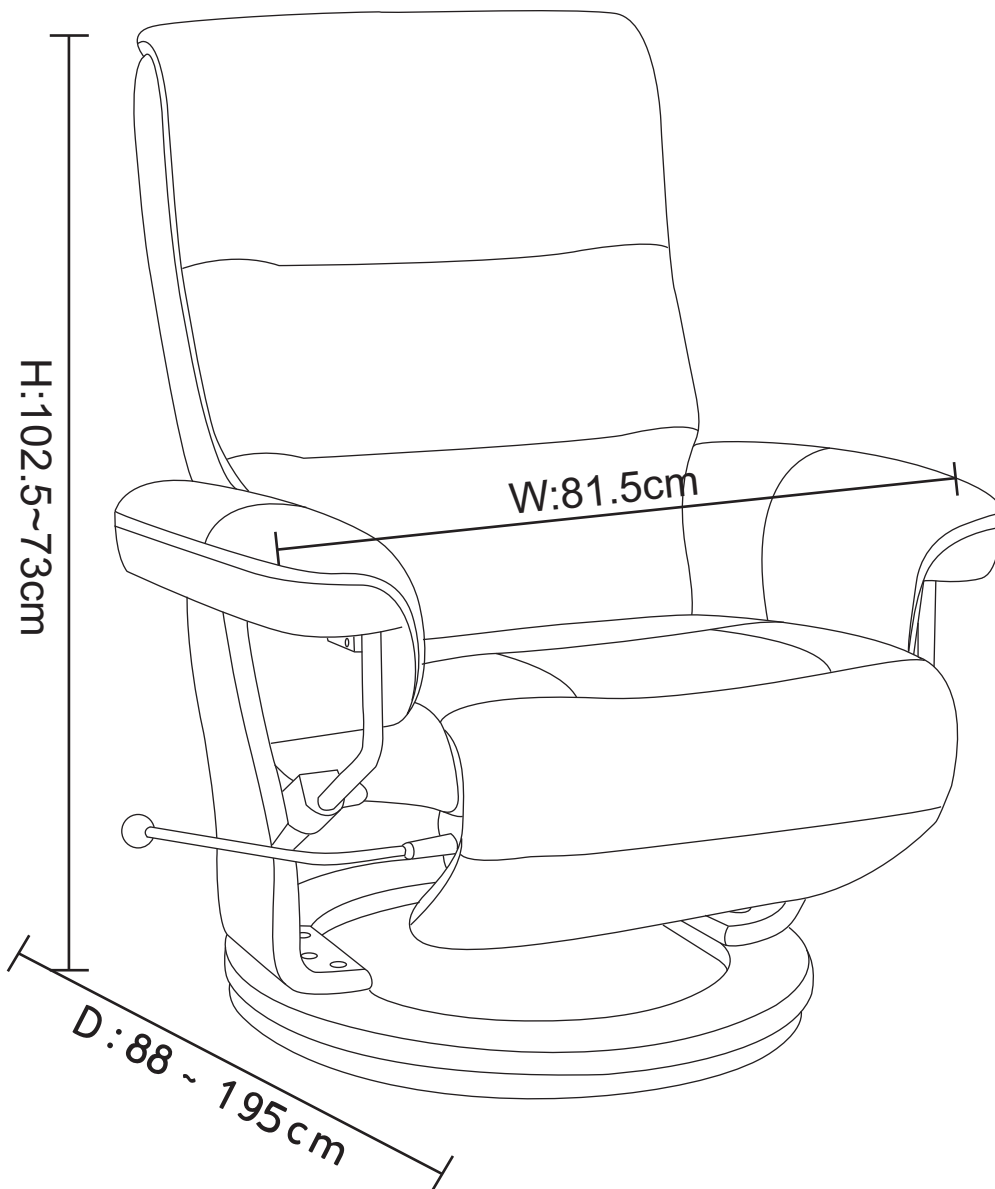

PRE-ASSEMBLY PREPARATION

Before you start:

1. Choose a clean, level, spacious assembly area. Avoid hard surfaces that may damage the product
2. Take care when lifting. Product should be assembled as near as possible to the point of use
3. Ensure that you have all required contents for complete assembly
4. Always read the assembly instructions carefully before beginning assembly.
5. Keep all hardware parts and packaging out of reach of small children.
6. Do not over tighten the screws and bolts as this may damage the threads

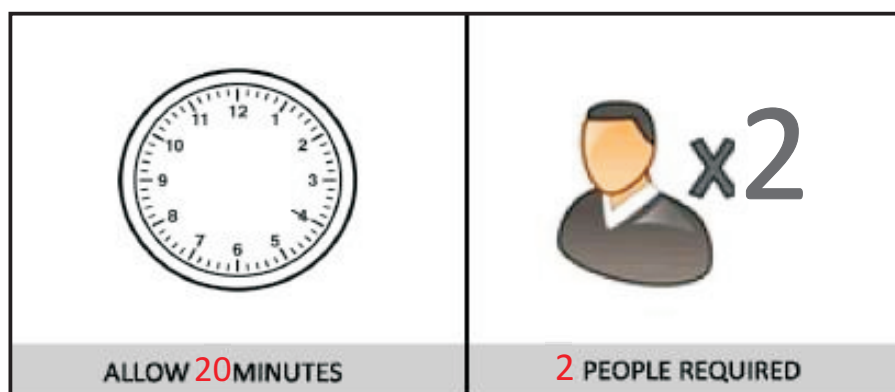

For any assistance for missing parts please refer to parts list on next page for identification.

Contact point of purchase or Furniture Solutions (Aust) Pty Ltd with below details

Email: customerservice@furnitureolutions.com.au





Free-call Australia PH: 1300 794 188

Website: www.furnitureolutions.com.au

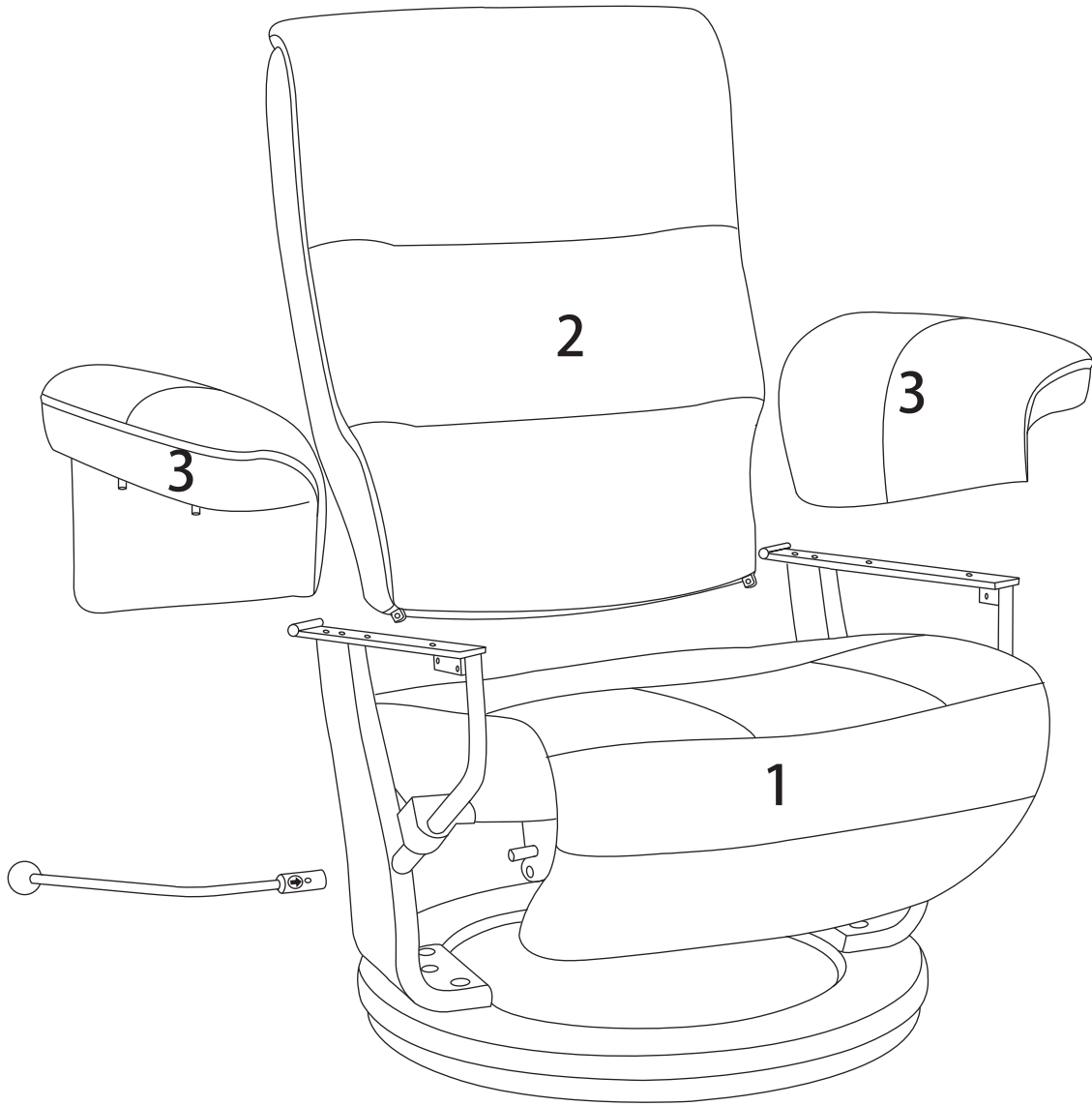
Note:

Please when contacting Furniture Solutions have purchase details and model name on hand

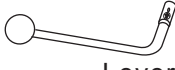
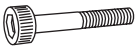

A	 M8X35	2PCS	C	 M6X20	4PCS	E	 Lever	1PC
B	 M8X70	2PCS	D	 M6X16	2PCS	F	 4mm/6mm	1SET

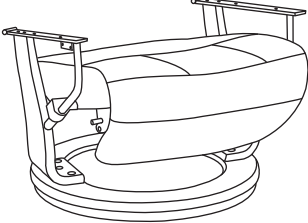
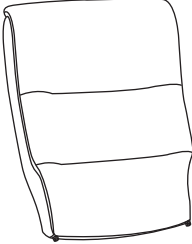
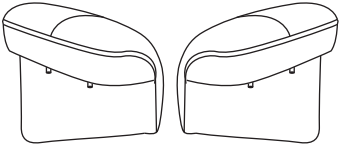
1.Chair Base With Build-In Footrest	2.Backrest Cushion	3.Armrest Pads
		

To Assemble Chair, attach backrest (2)

Take Chair base with cushion (1) place in upright position as shown in diagram, with the help of second person. Bring backrest (2) to chair base (1). Locate at base of backrest & back of seat black metal tubes that have holes, you may have to peel back leather covering to locate. Second person required to hold back rest level so bolts (A) can be inserted and seated into tread provided, and then by hand seat both bolts (A) to ensure not to cross thread. Once both seated correctly tighten with tool (F) tighten till you feel resistance, do not over tighten. Now attach upper section of back rest to back of black bracket as shown in diagram, again second person required to keep backrest square while fitting bolts (B). By hand start bolt (B) thru hole in bracket into backrest (2) again you may have to peel back leather covering to locate threaded hole. Once both seated correctly take tool (F) and tighten bolts. Note these bolts (B) are used as a pivot point for backrest movement and does not need to be tighten flat against metal.

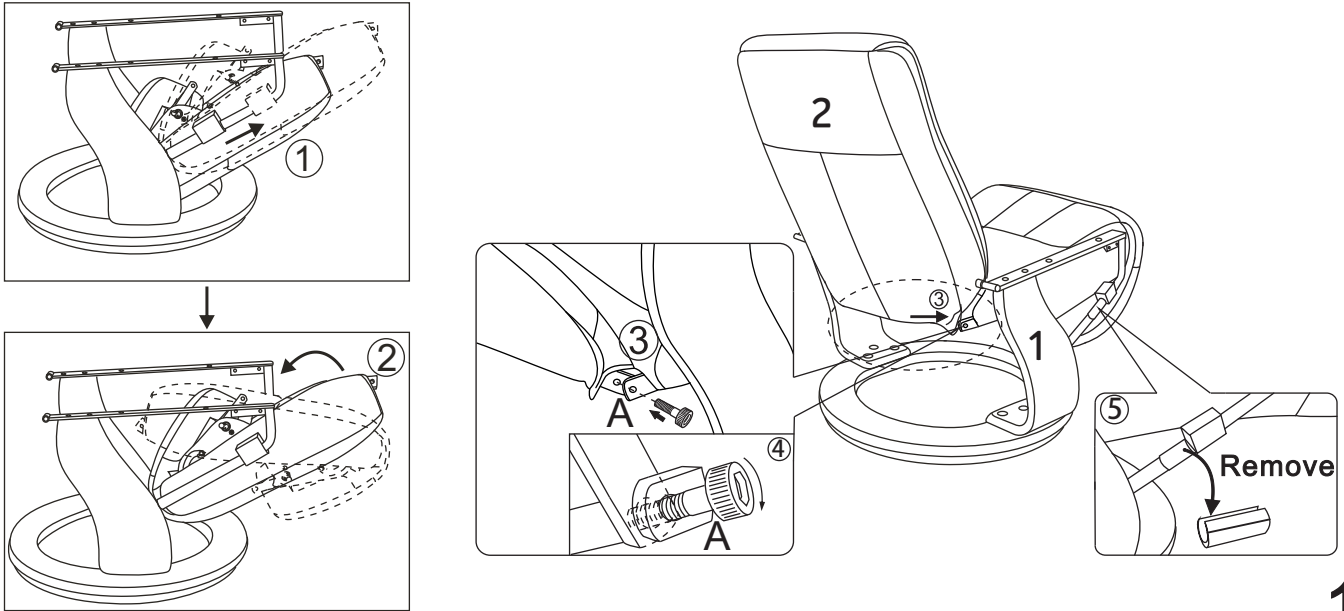

To attach Armrest: Place armrest (3) as indicated in diagram, line up holes in armrest (3) with holes on bracket. Using bolt (C) insert bolt thru hole in bracket and into armrest (3) then by hand seat bolt properly 2-3 turn, do not tighten till both bolts fitted by hand. Once both seated use tool (F) to tighten. Repeat for other side.

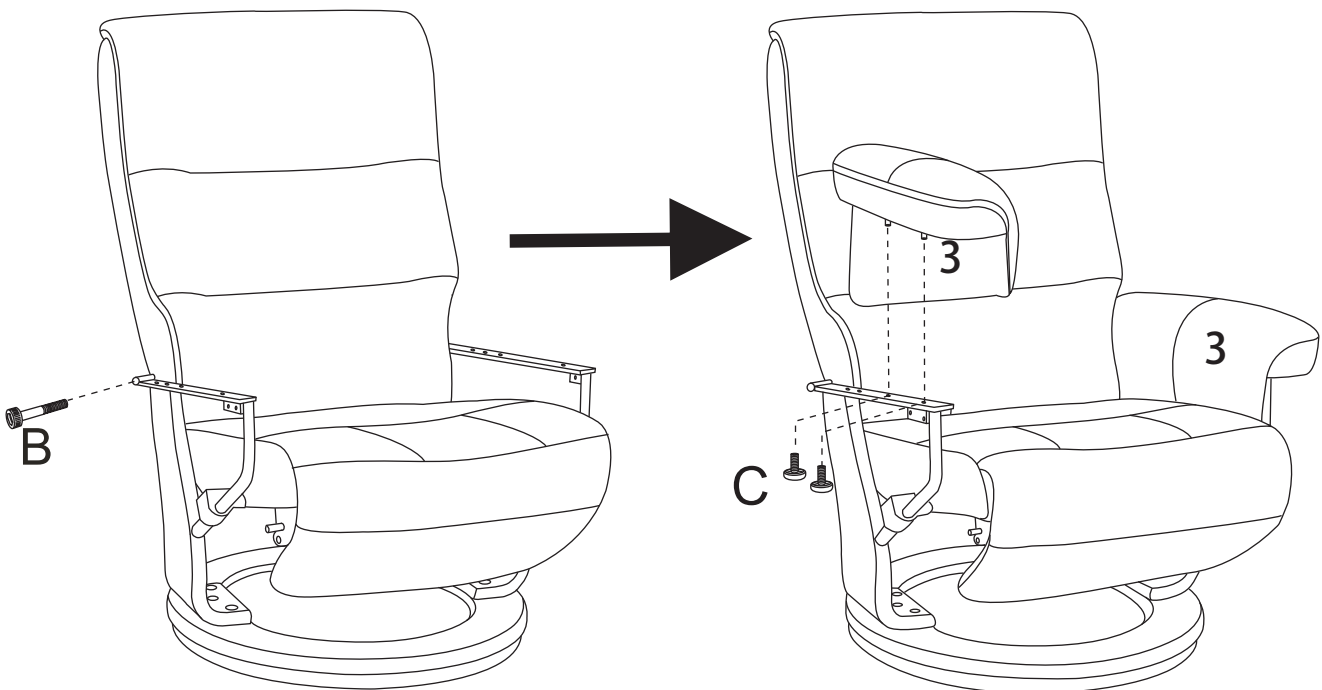

To attach Lever: Ensure footrest is in rest position under chair, take lever (E) with knob pointing to rear of chair line up the 2 red arrows slot lever (E) into position indicated on diagram, move around till holes line up, then by hand insert bolt (D) turn 2-3 times to ensure thread seated properly, once seated tighten bolt till firm. Then gently push lever forward till footrest is fully extended, this will expose a second hole, please repeat fitting as above. Assembly complete

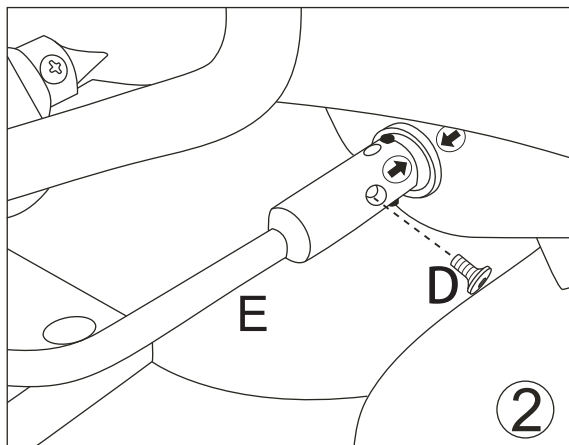
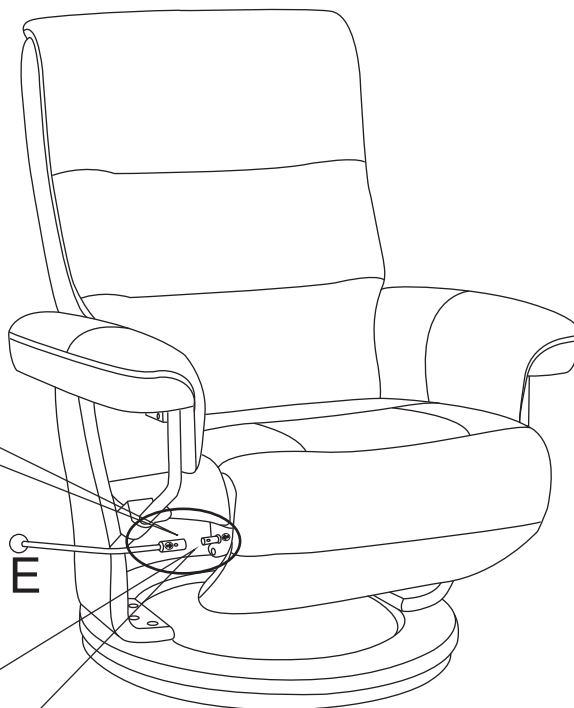
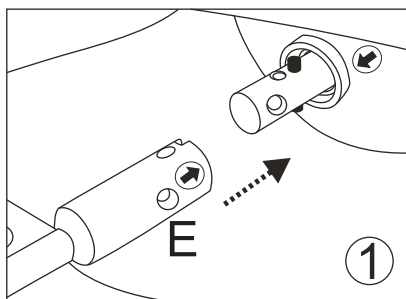

Be sure to push the handle to this position before you assemble the second bolt

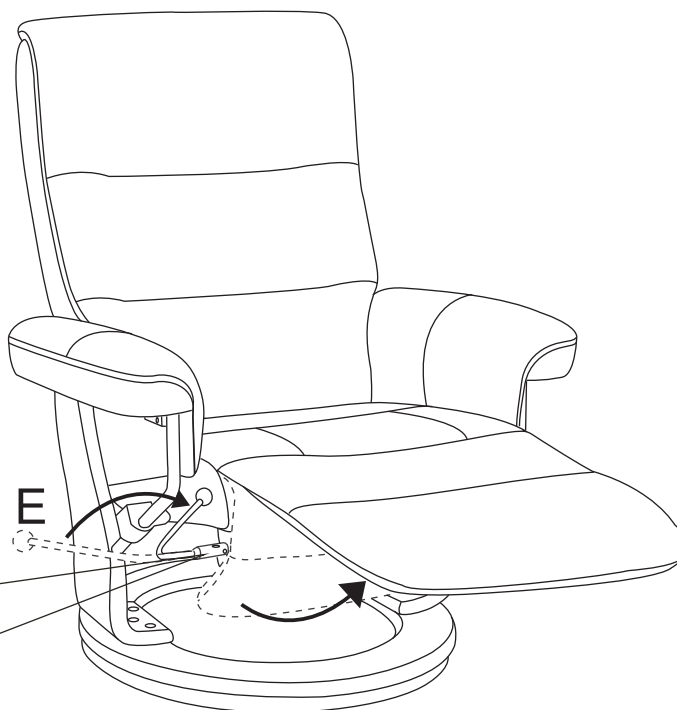
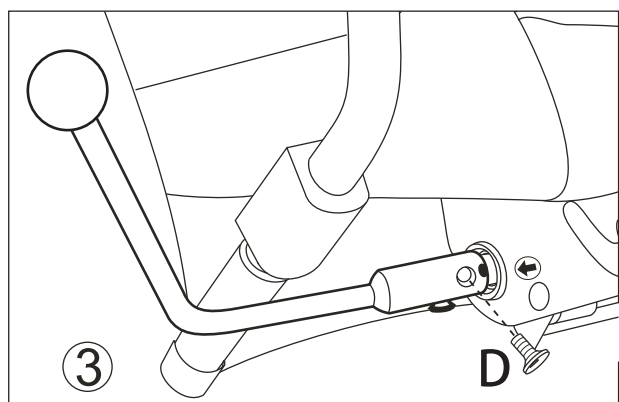

ASSEMBLY IS COMPLETE

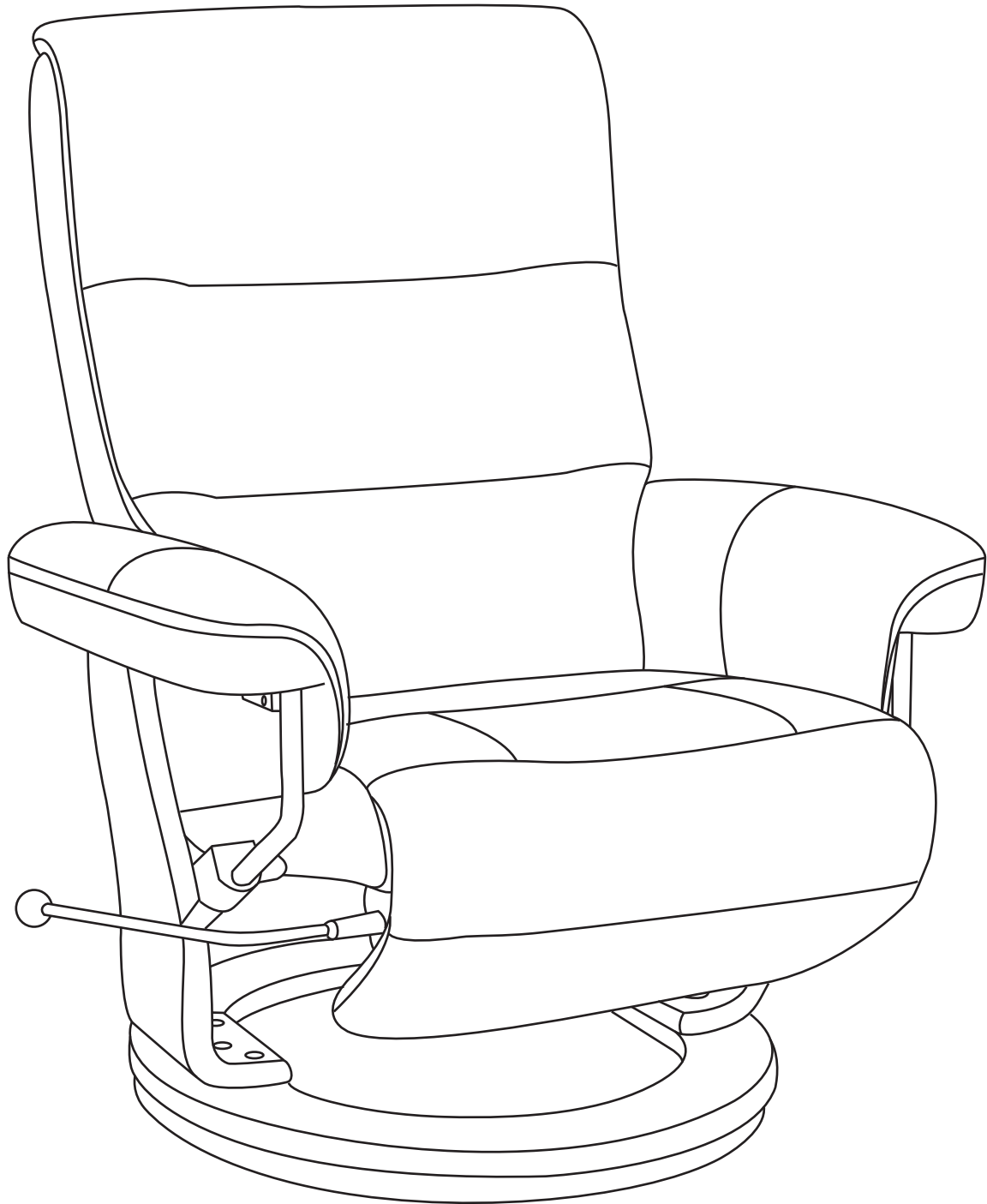

How to adjust the headrest



To adjust headrest: pull from back on both sides as shown.



Do not pull from side edge to adjust, material may tear



To return headrest back: push on both sides or use forearm to evenly move headrest back.

CAUTION

Do not push in the center of the headrest as this may cause foam cushion to collapse.

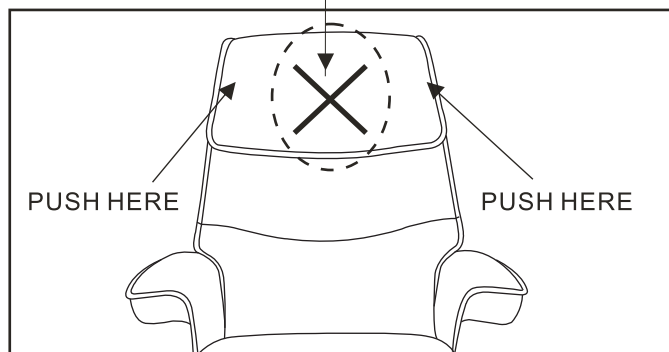

Hidden ottoman recliner operate instructions

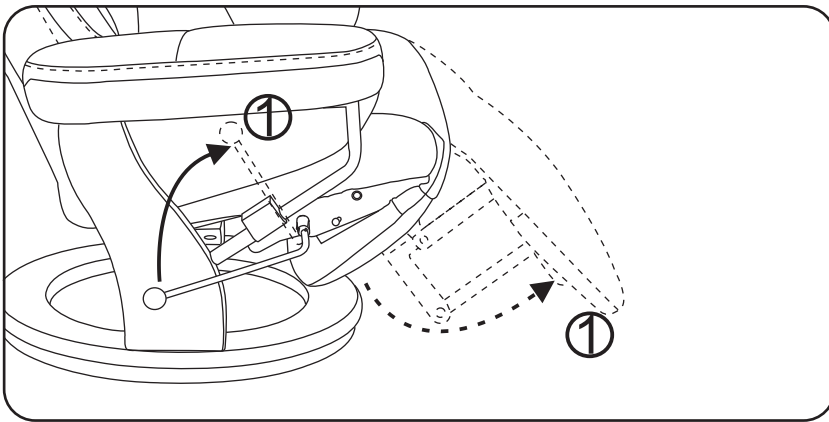

START (from lift in down-stow position)
Push lever forward to position ①

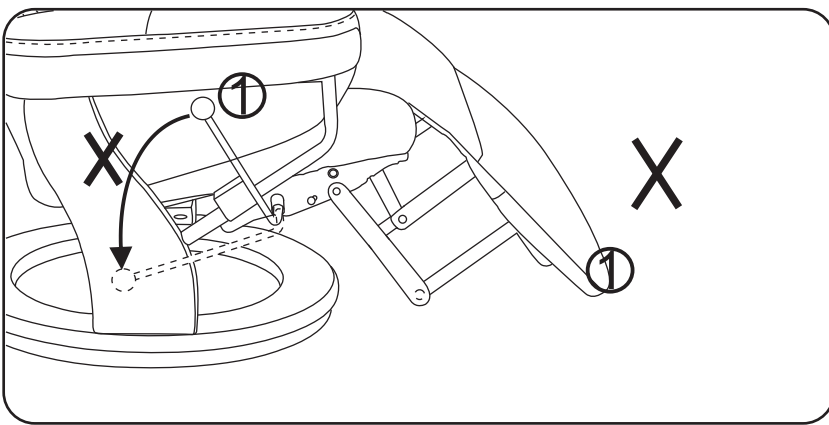

CAUTION!
Do not pull lever back from
this position ①

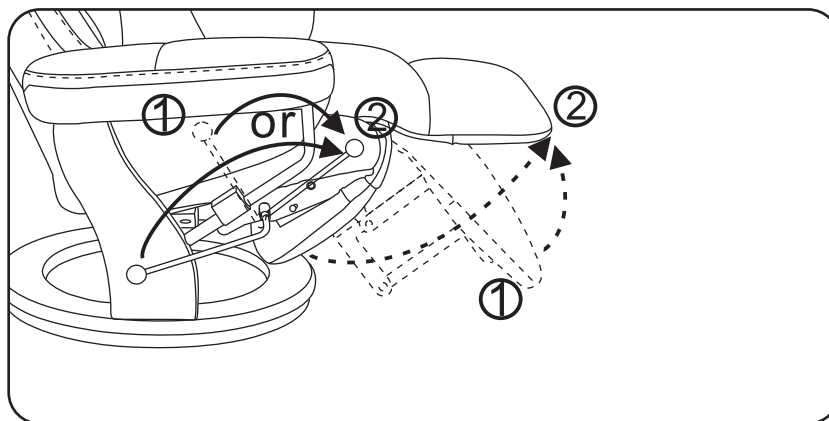

Push lever forward to position ②
or push lever forward straight to
position ② from down position

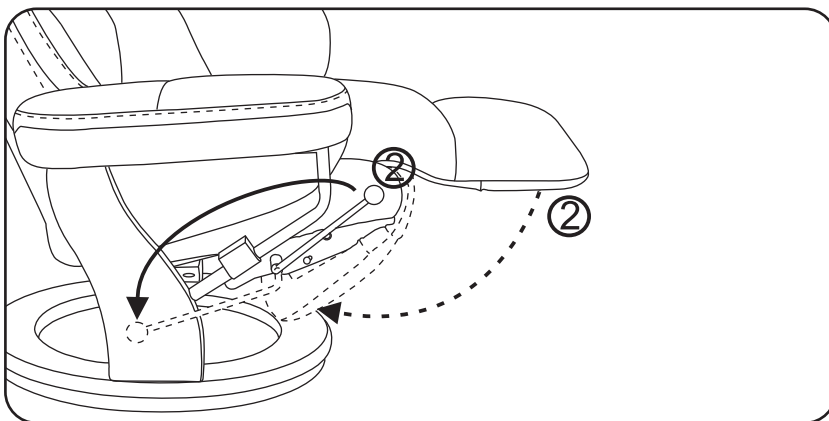

To stow lift from position ②
pull lever back to down position

Customise Your Recliner Action

Steps are shown as below

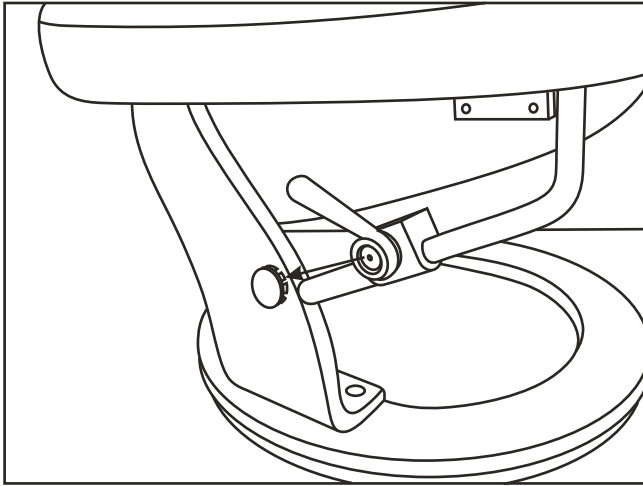

Take off plastic cover from handle.

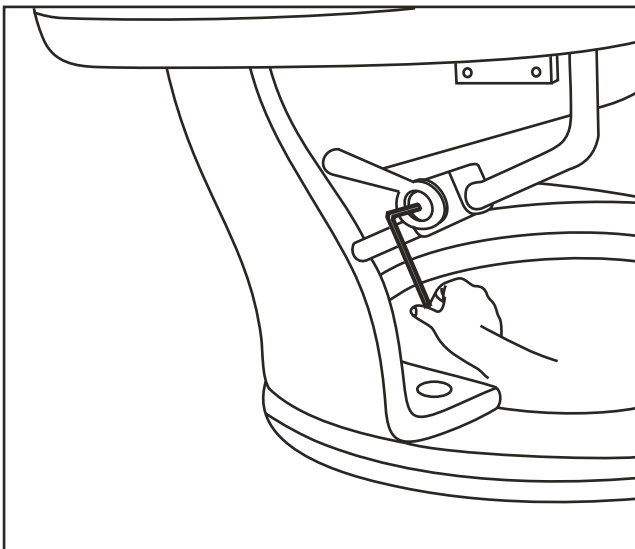

To adjust tension on glide action. With 4mm Allen Key adjust clockwise to tighten grip and anti clockwise to loosen. Note do not over tighten as handle will not lock properly.

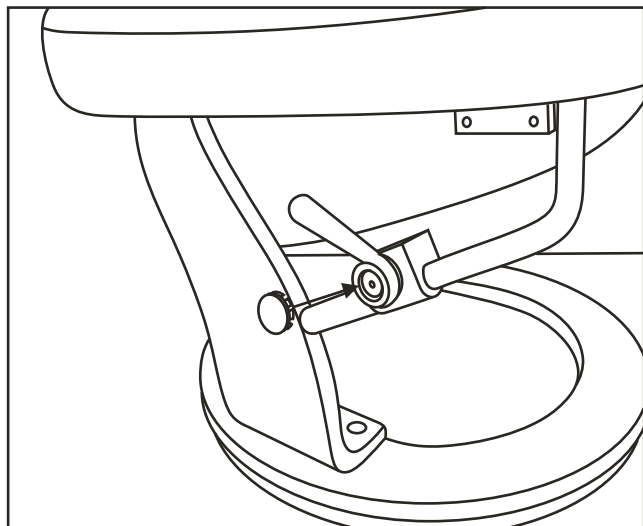

Put plastic cover back to handle bar.

Care Instruction for FABRIC covering

Regular Care:

Vacuum regularly using low suction

Treat spills and stains as soon as possible

Spot Cleaning:

Use only upholstery detergents

Apply proprietary cleaning agent strictly to instructions provided with product

Do not wet filing

Do not rub excessively

Do not use Solvent based cleaners

Do not use dishwashing or laundry detergent

Dry in shade away from direct heat & sunlight

Allow to dry before re-use

Periodic Cleaning:

Clean with hot water extraction machine. Professional cleaning recommended

Do not wash , Do not dry clean , Do not shampoo

Do not remove cushion covers for separate cleaning even though they may have zippers

Warning:

Protect from direct sunlight

Apply only water-based soil resist (fabric protection) treatments. Do not use aerosol products

Care Instruction for chair & mechanism

Every 3-4 months lay chair over on its back and wipe and or vacuum action inside chair to remove excess dust and fluff, pay special attention to swivel action at base of chair, ensure all metal components are clean and free of impediments.

Ensure all bolts are firm refer to assembly instructions for location.

Important safety instructions:

Do not sit on arms

Do not stand on chair

Do not lean on back of chair

Do not drag chair always lift with the help of another person

Do not allow items to be entangled with mechanism IE: Blankets, pillows & clothing

Ensure swivel mechanism on chair base is clear of loose threads, long carpet fibre's or similar items