

INSTRUCTION MANUAL

AKIRA 205CM EXT. DINING TABLE

ITEM CODE: 18AKIT08

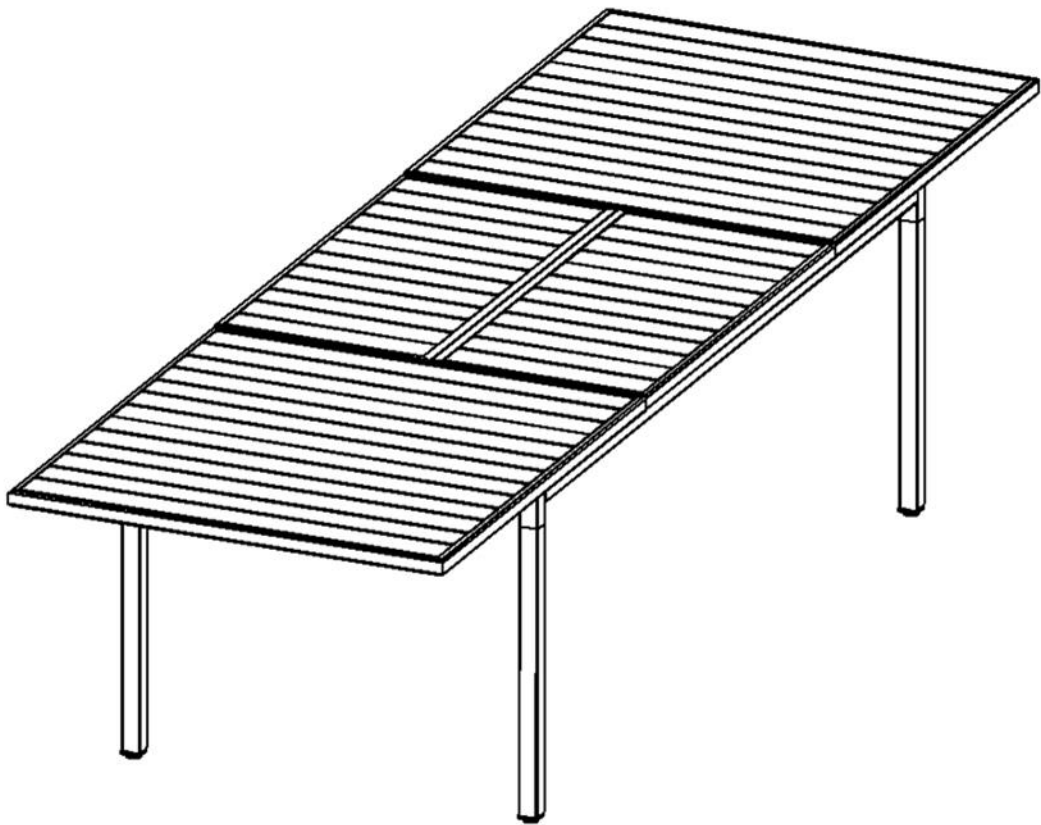

Imported by Furniture Solutions (Aust) Pty Ltd New South Wales, Australia.
For any assistance with assembly or for missing parts please contact:
Place of purchase or Furniture Solutions on below
Customer Service (Australia) Phone-1300 794 188
Email- customerservice@furnituresolutions.com.au

PRE-ASSEMBLY PREPARATION

Before you start:

1. Choose a clean, level, spacious assembly area. Avoid hard surfaces that may damage the product
2. Take care when lifting. Product should be assembled as near as possible to the point of use
3. Ensure that you have all required contents for complete assembly
4. Always read the assembly instructions carefully before beginning assembly.
5. Keep all hardware parts and packaging out of reach of small children.
6. Do not over tighten the screws and bolts as this may damage the threads

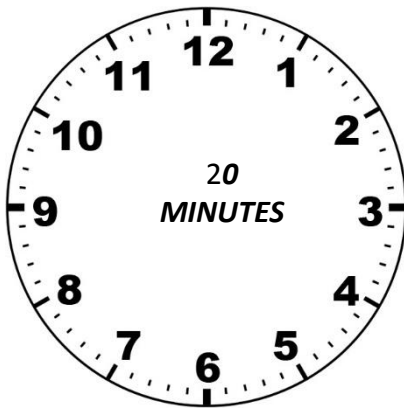

ALLOW TIME

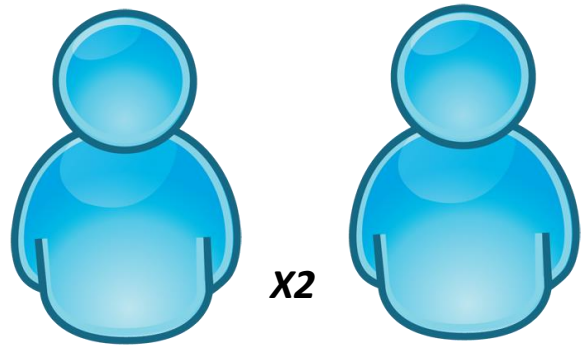

PEOPLE REQUIRED

WARNING:

The sunrays focusing across a glass may inflict burns to the table top. It is therefore strongly advised to avoid leaving glasses, vases, etc... in the sun, even in cloudy weather for a long time. Maintenance for the table top: small scratches can be removed using fine sandpaper and cleaned with a mild detergent.

Part list:

A		M4 Wrench	RM001	1PC
---	---	-----------	-------	-----

Table Top	P.TP6257.T3.T x 1
Table Leg	P.TP6257.T3.L x 4

ASSEMBLY INSTRUCTIONS

Please prepare work area as instructed in page 2:

To Attach Leg:

Please note before you insert leg you must loosen the grub screw inside table frame as shown in diagram below.

Take tool [A] and loosen the grub screw in leg casing, please look in from the top and wind screw anticlockwise until you do not see any thread showing.

Now slide leg into casing as shown in diagram with groove in leg facing corner with grub screw. Once leg is push in all the way in, take tool [A] again and tighten screw in a clockwise direction. Repeat same method on other three (3) legs. Move to Next page

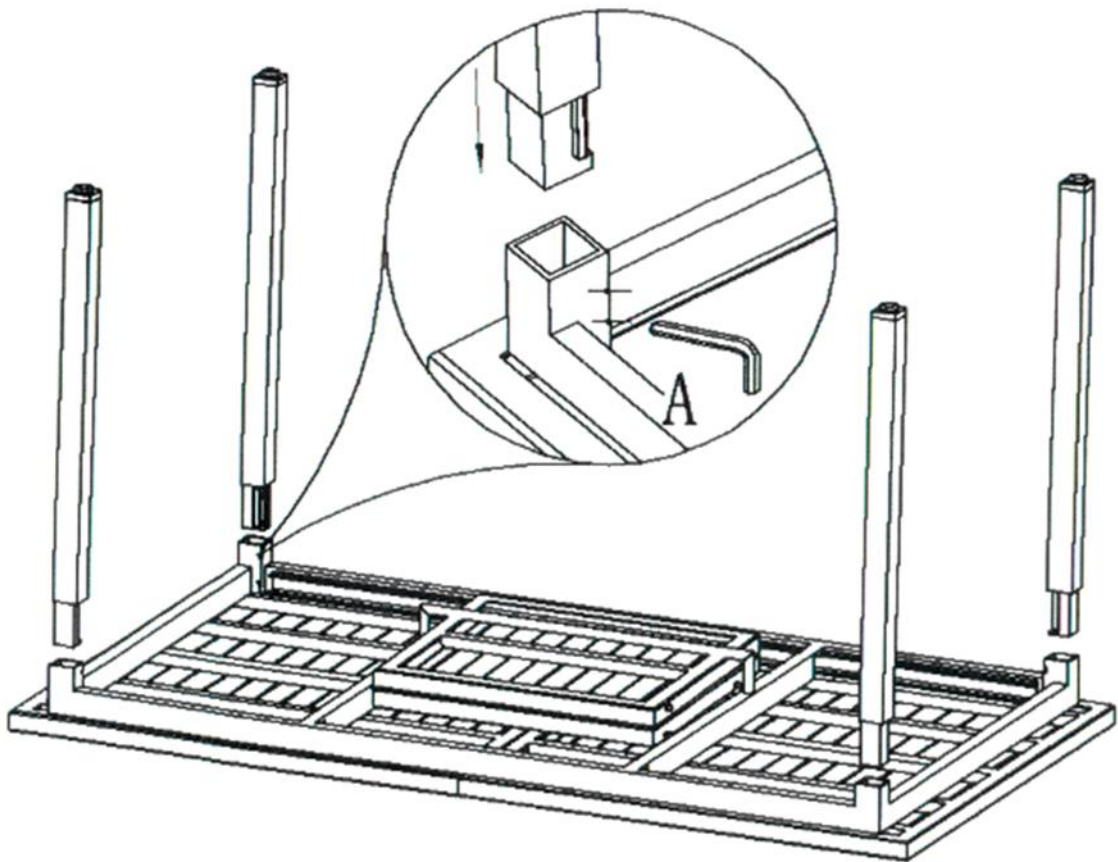

ASSEMBLY INSTRUCTIONS

Please prepare work area as instructed in page 2:

Once all 4 legs are attached, you need the help of extra person as you will need to lift the table into the air and rotate it in mid air. Once feet are level with ground lower table gently.

Please do not roll table over on its side to stand up you may damage the fitting under the table. Before use please read next page for operating instruction for extension piece.



OPERATION OF EXT. INSTRUCTIONS

Please note that to extend table there are two (2) locks engaged at factory. They are located under the table past the slide action, you will need to get under table to locate the first time. As shown diagram it is a toggle black in colour to release pull down and to lock push up. I recommend that all whom may operate this function be shown what is required to use ext. function.

Once both toggles are in the down position you can now open and close as desired.

Opening please stand in centre of table and with two hands one (1) on each of the edges of the table, pull top towards you and walk slowly backwards both section of the top work on a pulley system and one person can operate if required. Two is best. Ensure you extend fully.

Go to next page for more instructions.

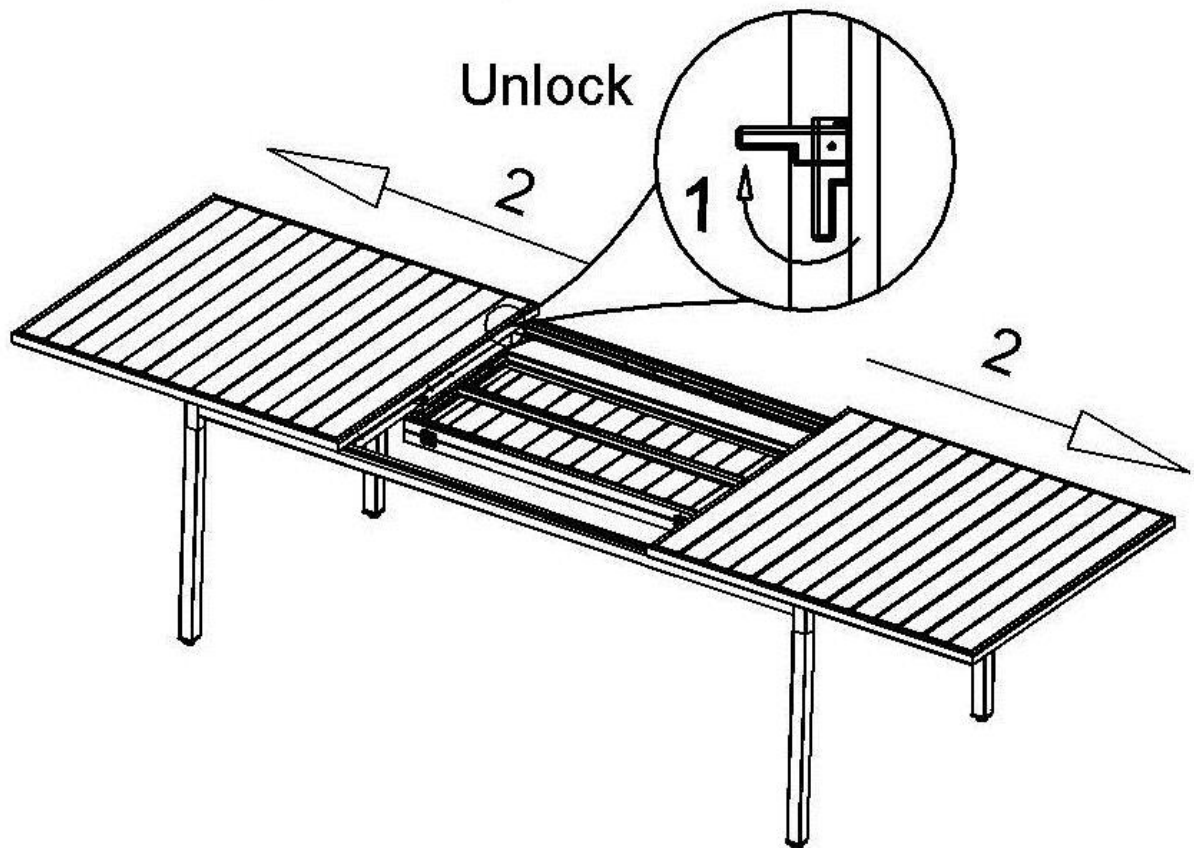

OPERATION OF EXT. INSTRUCTIONS

Once table is fully extended move around to middle of table, you will see the ext. piece folded in half. Before you move ensure that ext. piece has enough gap to open up as to not touch the two (2) table top panels. You will need to lift both piece together and fold over to opposite side of table rim, once task completed move to opposite side of table and fold over the top half only of ext. piece. Then once both pieces are sitting flat on the table rim. Move back to one of the ends and stand in centre of table and push on table top so that both tops interlock. Note you will need to engage locks to avoid table from opening up during use.

Please ensure all in house hold are acquainted with operation of table to avoid accidental damage from incorrect use. Now that you know how it all function just some do not's to be aware of.

Never drag table, always lift form the sides to move, lift only by the frame and not the table top. Please read care instruction before use.

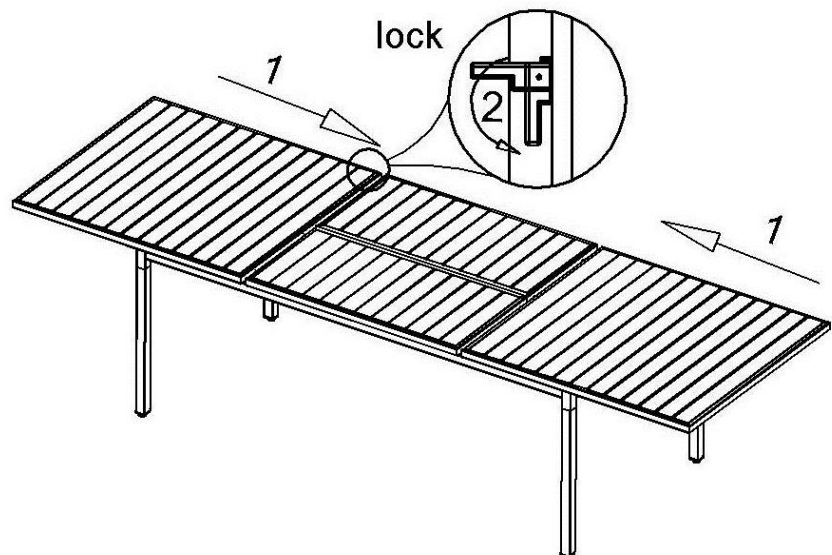
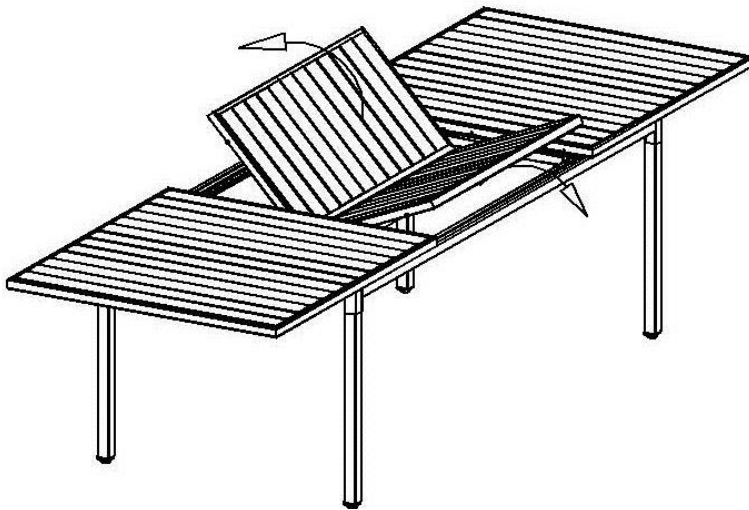

CARE AND MAINTENANCE

Varieties of materials are used in construction of “Outdoor” furniture range. All will require some form of maintenance to extend the life of finishes and general appearance. Please see below instruction unique to your chosen product.

Akira Construction;

Frame: Powder coated aluminium

Top: Faux Timber “Poly-Wood”

Textilene Fabric:

Powder Coated Aluminium;

Powder coating is similar to a painted finish, the metal is coated with a paint powder then is past thru a kiln to bond and harden paint onto metal.

Please follow below for regular cleaning

Bucket of warm water with a soft clean cloth or sponge, clean metal in one direction, do not rub excessively. Ensure to pat dry as water drop will leave a mark on paint finish.

Faux Timber Information;

Faux Timber is know as Poly-wood or plastic lumber is composed of virgin or waste plastics including HDPE, PVC, PP, ABS, PS and PLA. Additives such as colorants & stabilizers are introduced during melting process to ensure bonding to plastic at a cellular level.

It is water resistant and resists all types of rot and mould. Although it is not as rigid as wood. Being made of a plastic material the affect of hot weather will cause the material to become soft and supple which can cause surface to deform.

Items made of glass that can amplify the heat can affect the surface of Faux Timber.

Care should be taken to use table cloths and placemats to avert marking Poly-wood.

Cleaning Polywood;

Use a bucket filled with warm water & a soft soap, sponge all over till clean then rinse with clean water. Using a soft clean cloth wipe till dry. For stubborn stains a mixture of 1/3 bleach and 2/3 water using a soft non-metallic brush, please rinse thoroughly with clean water and dry as above. Some scratchers and marks can be sanded out depending on surface of Polywood please contact Furniture Solutions before attempting to repair.

Definition of Regular Cleaning;

Numerus factors can influence the time frame for cleaning, depending area you live in, the weather, positioning of the product (fully protected, partial protection, fully exposed to the elements). You will need to monitor yourself to establish the cleaning requirement for your unique situation.

Areas with high salt content and or pollution will require the most frequent cleaning.

To reduce some maintenance you should buy and use an outdoor cover to protect your furniture from the elements when not in use.

SAFETY WARNINGS AND ADVICE

Notices and Advice

Please be advised that products are limited in design for residential use only and are not suitable for commercial use.

Please be advised that materials used in your furniture are not impervious to neglect, acts of god, abuse, alcohol spills, improper use of chemicals such as bleach or any solvent based products.

Please be advised that heat sources such as barbeques, open fires, temporary/mobile/overhead heaters, poorly insulated candle holders, hot pots, pans, hot serving dishes can have adverse affects on your furniture.

Please be advised to use properly insulated placemats and coasters when serving hot or cold dishes and drinks.

Please be advised that fitting, bolts, nuts and or screws should be checked periodically to ensure they have not loosened over time. Remember do not overtighten.

Please be advised coverings and paint finishers are not animal proof. Claws can scratch covering & saliva is acidic and can damage finish.

Please be advised that continues exposure to the elements will reduce the life of finishes and fittings.

Faux timber is made up of plastic material, be aware that high temperatures will soften the lumber panels, please keep out of direct sunlight at all times, ensure hot or cold containers have sufficient insulation between surface of table and said container IE: Coffee cups, plates with hot food, do not place of surface at any time candles, fry pans & any other utensil that retains heat. Always use place mats made of cork, tile or wood. Fabric place mats provide no protection from heat.

DO NOT

- Place in close proximity to open flame or heaters.
- Leave spills or food, clean off immediately
- Pull loose thread, cut them instead.
- Sit or lean on arms or top of chairs
- Stand on chair or bench's
- Stand on table tops
- Place heavy objects on table tops
- Place objects such as pot plants as a display piece on tables recommend weight restriction for table top is 60kg across the table

Safety warnings

- DO NOT:
- drop, drag, always move furniture with the help of another person to lift and place only
- over load seats designed for single adult use.
- use tables, chair, sofa as work bench's or substitute ladders.
- allow child to play under table.

Warranty Detail:

1 Year Warranty

A one (1) year warranty applies to product against any defect associated with faulty workmanship for a period of (1) year from date of purchase.

Furniture Solutions accepts no responsibility for defects caused by incorrect assembly, mishandling, acts of god, general wear & tear, stains from spills/vegetation, chipping/scratching, exposure to extreme heat/cold, mould/mildew, hardware corrosion, misuse of the products & defects caused by failure in duty of care for the product in accordance with the care instructions.

Warranty only extends to original purchaser and is not transferable, except when given as a gift. Goods are limited in design for domestic use only, and are not suitable for commercial use.

Duty of care:

While every attempt is made to supply product using quality components there is always a need from consumer to help ensure a long life of use for product.

*Proper use of item, only what it is designed to do. Designed for dining, not suitable for use as a workbench, substitute ladder or dance floor.

***Regular maintenance and** cleaning: Please consult your Instruction manual included in packaging for advice of cleaning

***Protecting product from the harsh environment: Pollution, excessive moisture & heat.**

To extend the life of your outdoor furniture we recommend the following furniture covers must/should be used on furniture which is used in areas not protected from elements.

Caution should be used when using oils, lotions & other chemicals such as chlorine not to spill on furniture.

Instruction Manual – Have been written to suit individual materials used in construction, please retain for future use for duty of care, assembly, parts & component sizing.

Claim management:

To make a warranty claim, customers can either contact the retailer where the purchase was made or Furniture Solutions on contact details below. Proof of purchase will be required before proceeding with any claim. In the case of product defects providing photos may be able to speed up processing of the claim. If missing parts please refer to assembly instructions for identification of said part and contact either of the above.

“Our goods come with guarantees that cannot be excluded under the Australian Consumer Law. You are entitled to a replacement or refund for a major failure and for compensation for any other reasonably foreseeable loss or damage. You are also entitled to have the goods repaired or replaced if the goods fail to be of acceptable quality and the failure does not amount to a major failure”.