

= Furniture Solutions =

Chena Recliner with Footstool

PRE-ASSEMBLY PREPARATION

Before you start:

1. Choose a clean, level, spacious assembly area. Avoid hard surfaces that may damage the product
2. Take care when lifting. Product should be assembled as near as possible to the point of use
3. Ensure that you have all required contents for complete assembly
4. Always read the assembly instructions carefully before beginning assembly.
5. Keep all hardware parts and packaging out of reach of small children.
6. Do not over tighten the screws and bolts as this may damage the threads

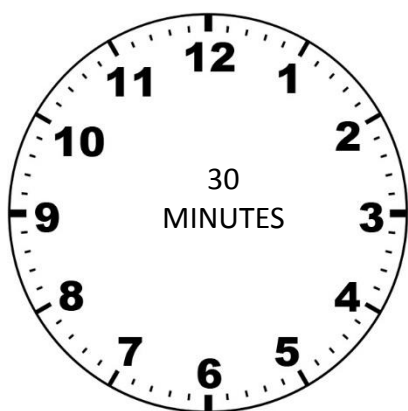



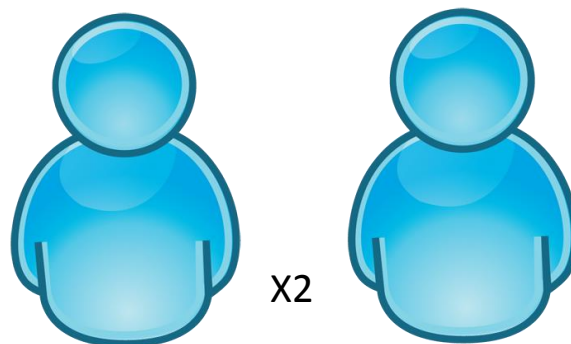



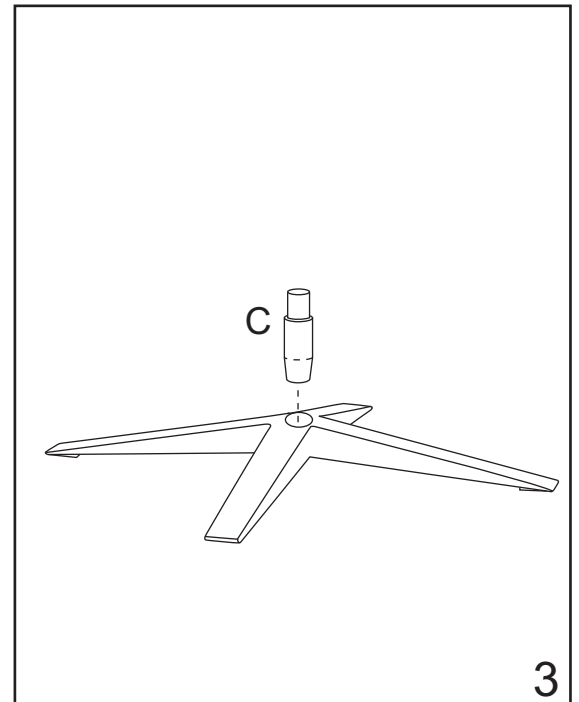
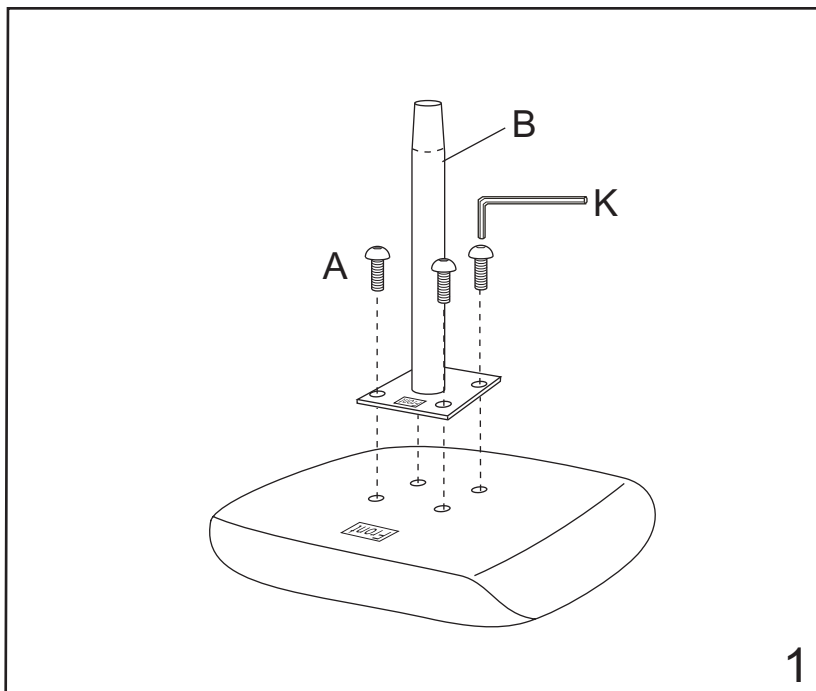
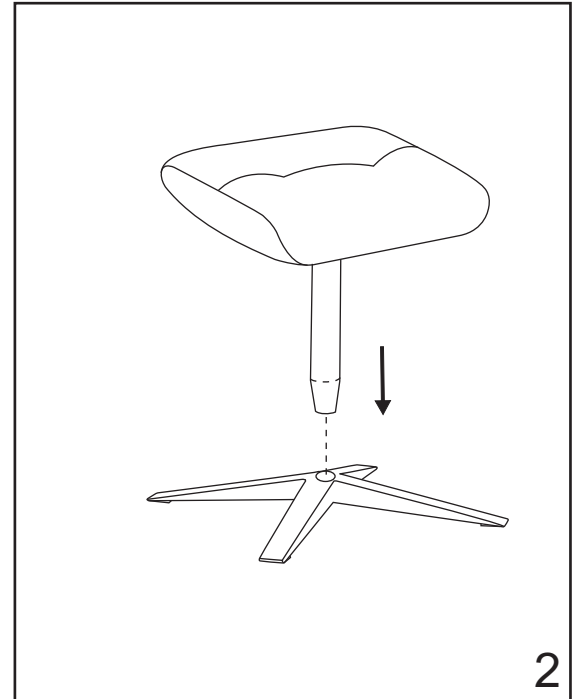

ALLOW TIME

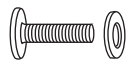
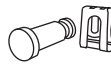
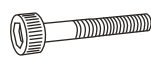

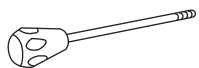
PEOPLE REQUIRED



A	 M6X20	4 PCS	B		1 PC	C		1 PC
D	 M8X38	4 PCS	E		2 PCS	F	 M8X35	2 PCS
G		2 PCS	H		1 PC	I		1 PC
J		1 PC	K		1 PC			

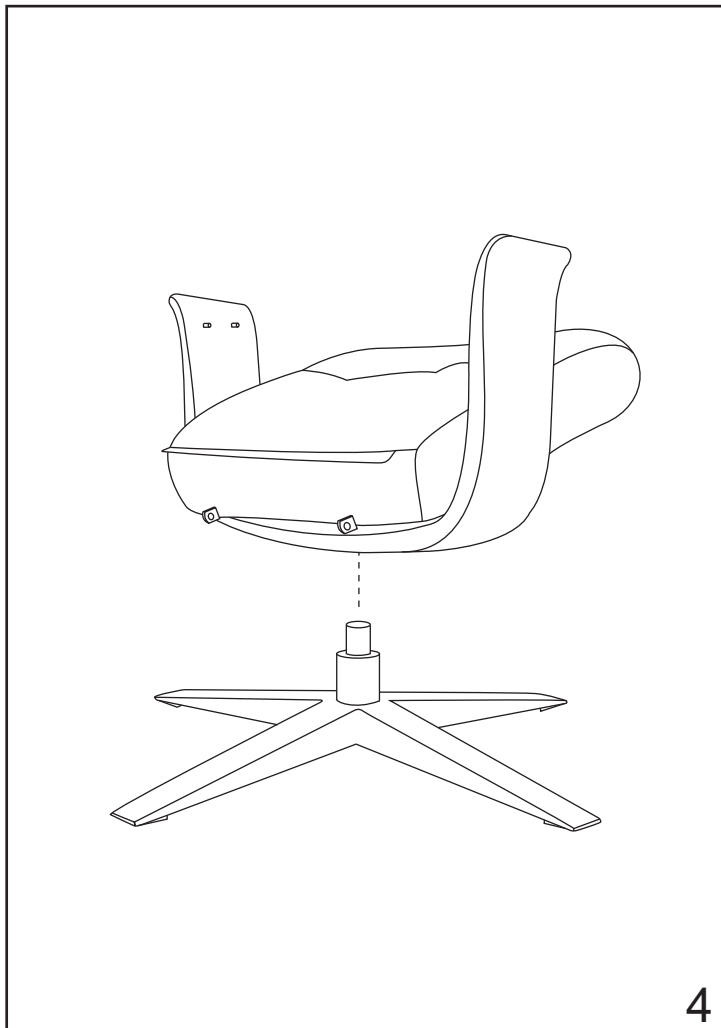

4

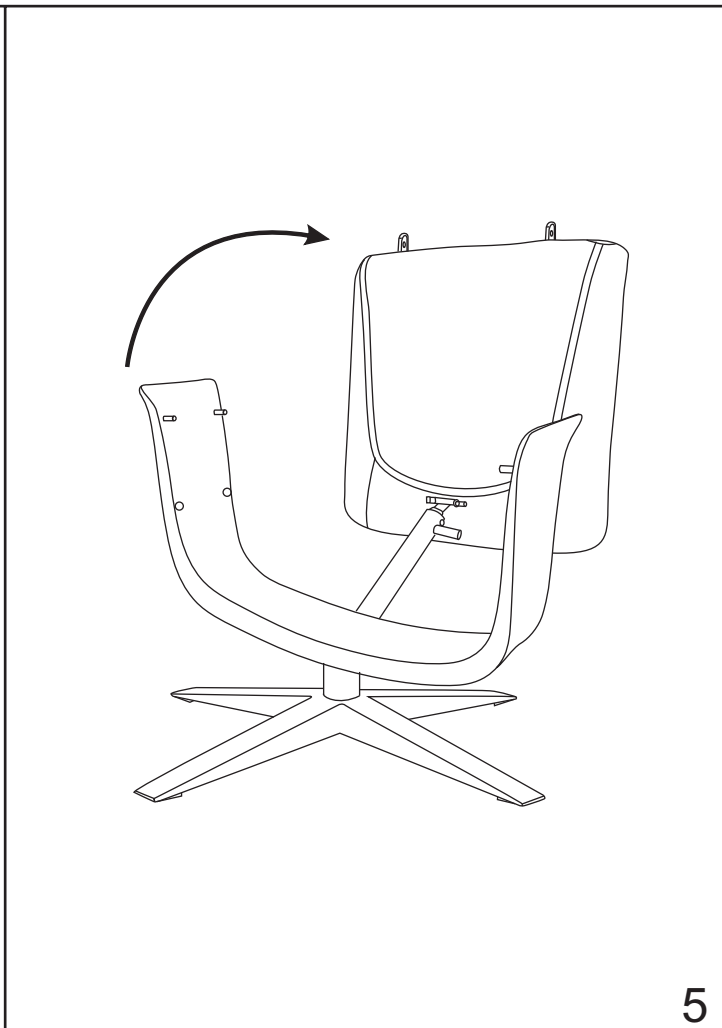

5

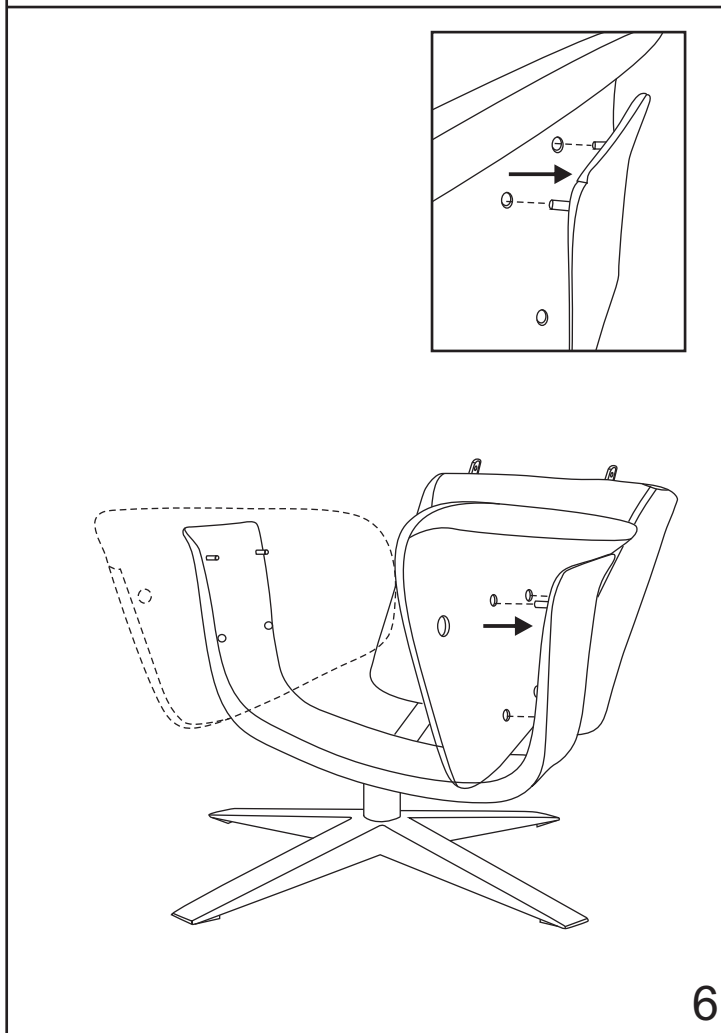

6

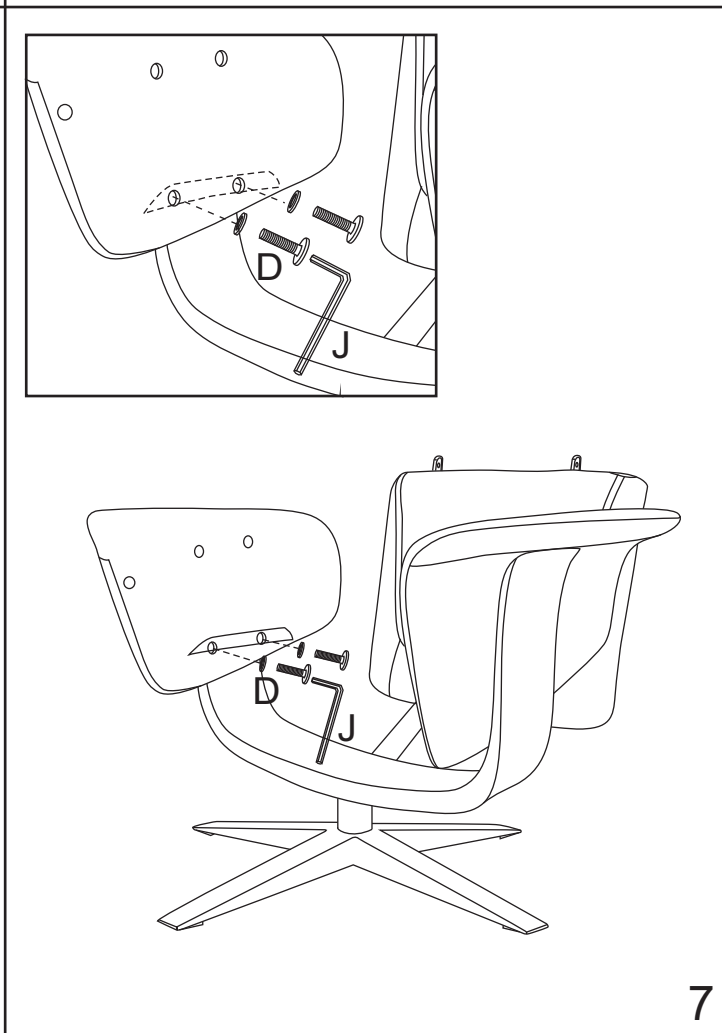

7

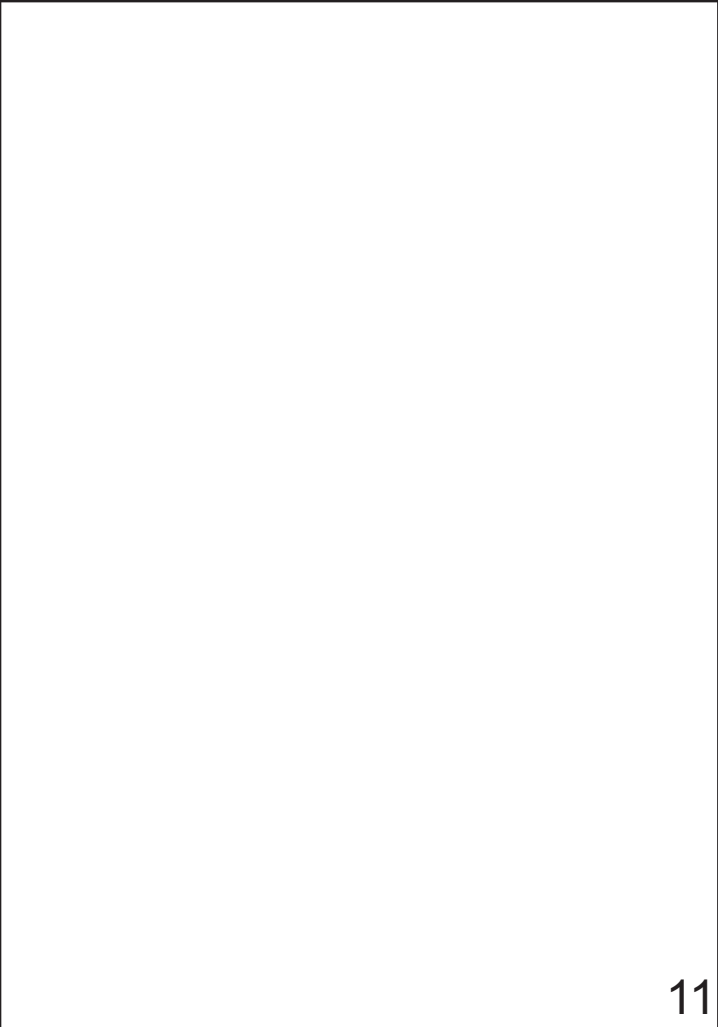
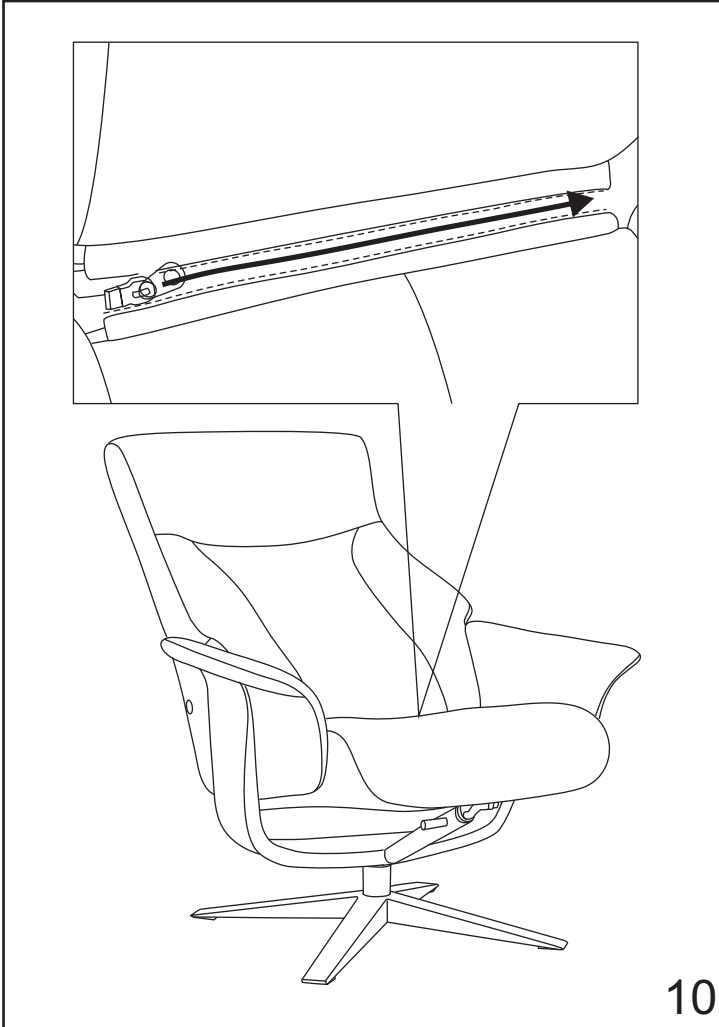
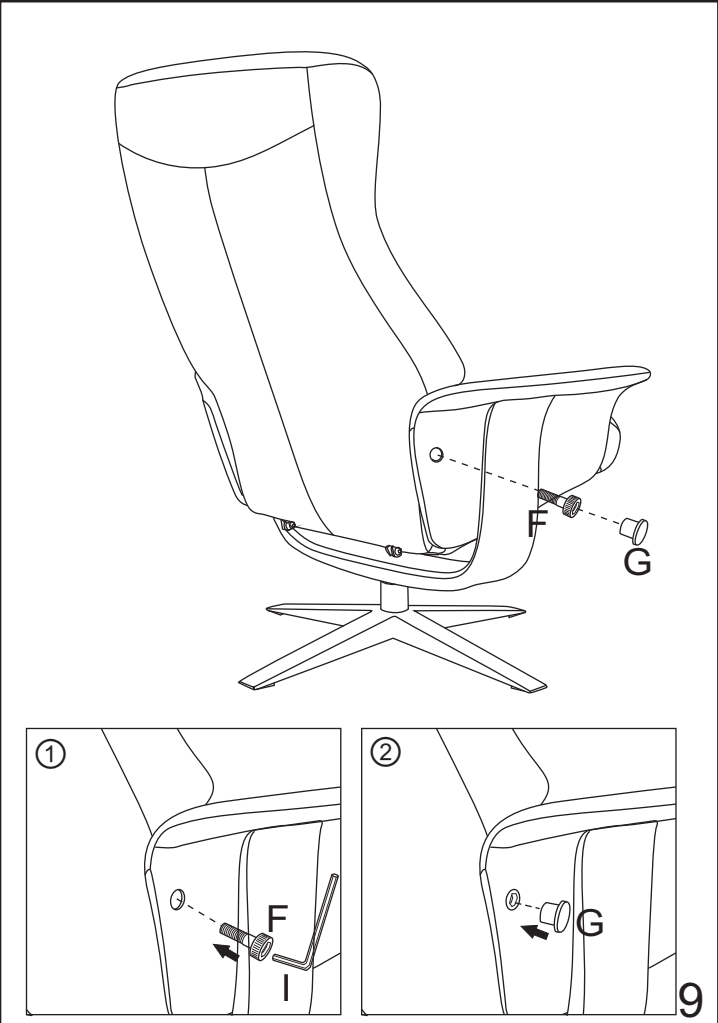
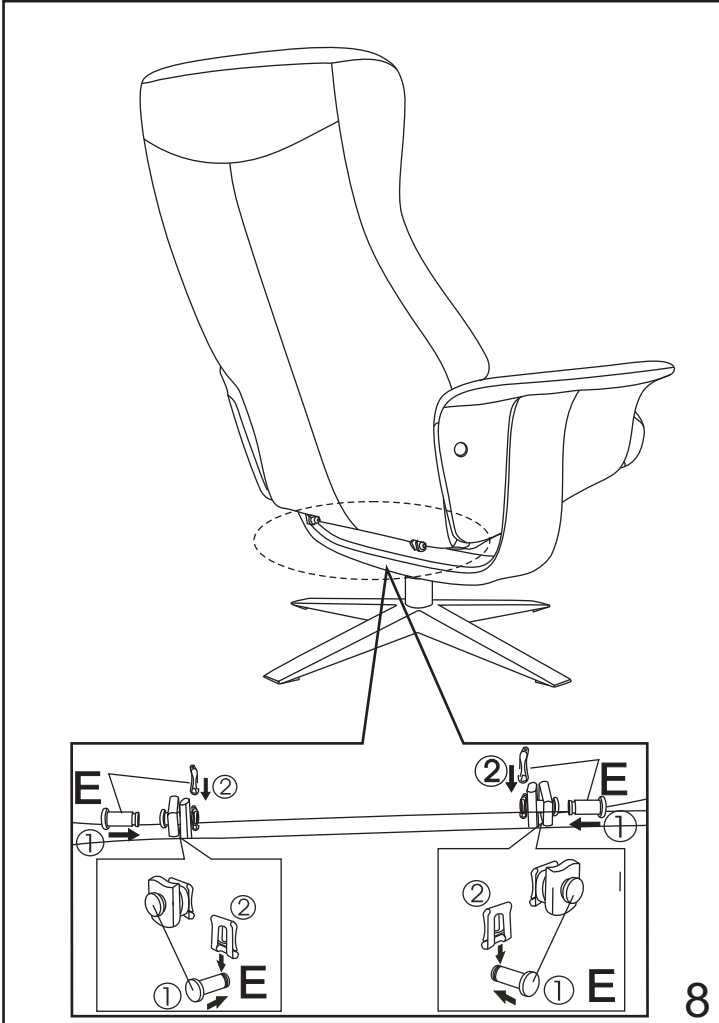

FEATURES AND OPERATING OF RECLINER

Operation of Recliner:

Locking of backrest in desired position.

The locking mechanism is design for variable recline positions, so you can find the preferred angle for sitting.

Turn knob (locking arm) clockwise to lock and anti clockwise to loosen.

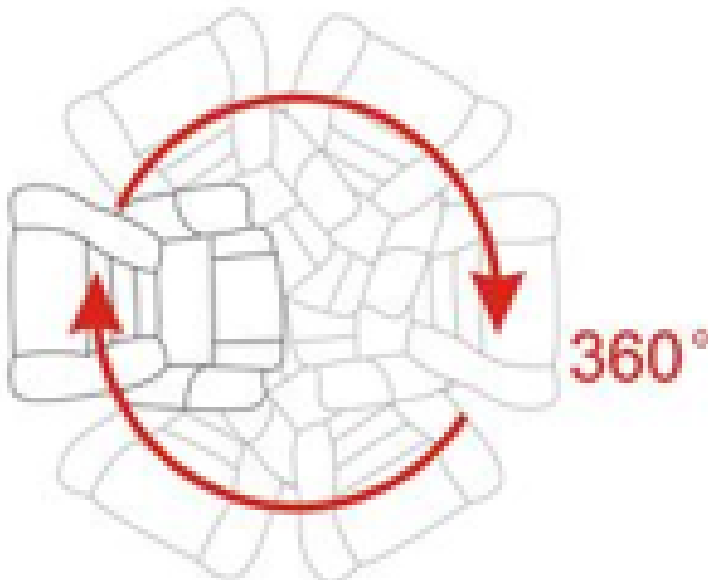
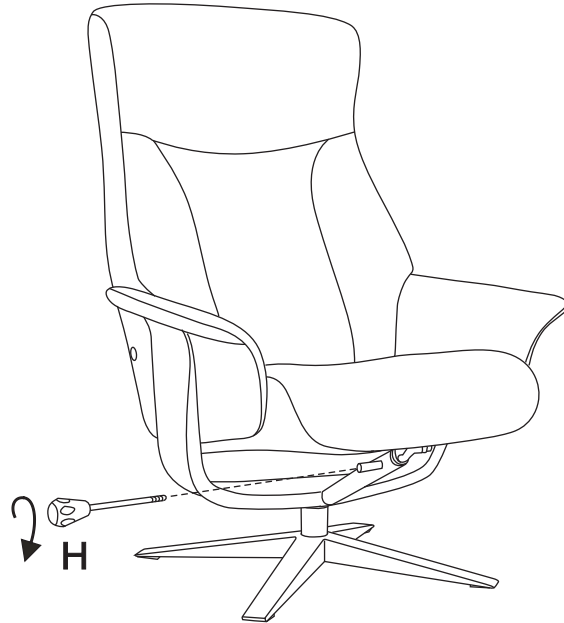

FEATURE:

Swivel base.

Complete 360 degree turning circle.

How to adjust the headrest



To adjust the headrest, grip the backside of the headrest and pull forward from both sides as shown



DO NOT pull from the side edges, as the material may tear



To adjust the headrest backward, push on both sides or use a forearm to evenly move the headrest

Caution:

Do not push in the center of the headrest, as this may cause the cushion to collapse

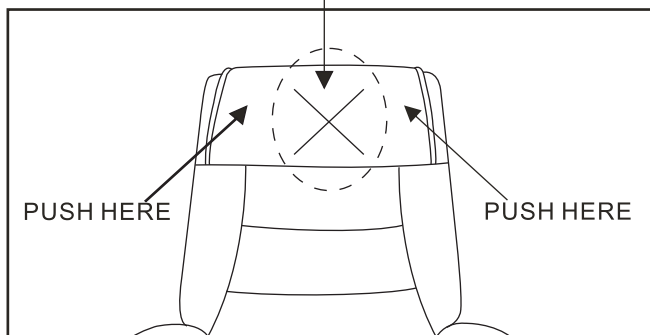

CARE AND MAINTENANCE

Varieties of materials are used in construction of "Recliner" furniture range, Such as Stainless Steel; Nickel plated steel; Chrome plated steel; Powder coated steel; Timber, Leather, PU synthetic fabric & a variety fabrics.

All will require some form of maintenance to extend the life of finishes and general appearance. Please see below instruction unique to your chosen model.

Zarrah Recliner Chair and footstool

Covering : Leather Full Hide with Corrected Grain

Base : Nickel plated steel

Leather Covering;

Keep dust free at all times.

Regular use a damp soft clean cloth and wipe down leather.

Pay special attention to areas where skin touches leather. IE : Armrest Pads, Headrest, front section of chair and footrest tops.

Please clean up spills immediately. Ensure to dry properly before use.

Periodic Leather Cleaning;

Every 3-4 months you need to give leather a good clean to remove excess body oils.

Please purchase a propriety leather cleaner and follow all directions indicated on packaging.

You could also purchase a leather conditioner/protector to complement the leather after a good clean.

Frequency of periodic cleaning can vary due to colour of leather, use and environment.

A chair used 2 hours a day will require less cleaning than a chair used 8 hours a day.

Areas of high humidity will require more cleaning than areas of low humidity.

Professional Cleaning;

Even the most diligent house keeper cannot always prevent leather from aging or looking tired.

We recommend you use the services of a reputable leather cleaning service when your cleaning does not appear to make a difference in appearance.

Things to know about leather;

The surface of leather can be affected by chemicals used in hair spray, gel, mousse, perfume, deodorants, some medications, alcohol and dye transference from clothing. Please factor this into your cleaning regime.

Nickel Plated Base;

Please remove dust and grit on metal as required.

When grease stains and tarnish begin to appear, you'll need to clean off your plating. By washing first with warm water, using a metal cleaner for persistent blemishes, and then polishing, you will keep your nickel plating strong and lustrous for years to come.

SAFETY WARNINGS AND ADVICE

Notices and Advice

Please be advised that products are limited in design for residential use only and are not suitable for commercial use.

Please be advised that materials used in your furniture are not impervious to neglect, acts of god, abuse, alcohol spills, improper use of chemicals such as bleach or any solvent based products.

Please be advised that heat sources such as direct sunlight, log fires, heaters and air conditioners can have adverse affects on your furniture.

Please be advised that fitting, bolts, nuts and or screws should be checked periodically to ensure they have not loosened over time. Remember do not overtighten.

Please be advised coverings are not animal proof. Claws can scratch covering & saliva is acidic and can damage finish of covering.

DO NOT

- Place in direct sunlight.
- Place in close proximity to open flame or heaters.
- Place in direct line of air conditioning ducting.
- Leave spills or food on sofa clean off immediately
- Pull loose thread, cut them instead.
- Sit or lean on arms
- Stand on chair

Safety warnings

- DO NOT:
- drop, drag always with the help of another person lift and place, to avoid damage to floor surface & base of recliner chair.
- Sit on arms or back when upright, this could damage internal mechanism.
- Fold mechanism with linen or cushions on sofa.
- Pull loose thread, cut them instead.
- Jump, flop or stand on sofa.
- Always release both glide handles before you attempt to move into upright position.
- Ensure swivel mechanism on chair base is clear of loose threads, long carpet fibre's or similar items

WARRANTY DETAIL

2 Year Warranty

A two (2) year warranty applies to product against any defects associated with faulty workmanship for a period of (2) year from date of purchase.

Furniture Solutions accepts no responsibility for defects caused by incorrect assembly, mishandling, acts of god, general wear & tear including fading, creasing of covering, aging of foam and fibre filling IE Height reduce over time, stains from spills, chipping/scratching, exposure to extreme heat/cold, mould/mildew, hardware corrosion, misuse of the products & defects caused by failure in duty of care for the product in accordance with the care instructions. Warranty is based on normal household use and not for commercial use. Warranty only extends to original purchaser and is not transferable, except when given as a gift.

Notice:

While every effort is made to use quality materials our products are limited in design for domestic use only & are not suitable for commercial use. Care should be taken not to place product near heat sources.

Duty of care:

While every attempt is made to supply product using quality components there is always a need from consumer to help ensure long life of use for product. Instruction manuals are designed with the nature of materials used in construction of the product.

*Proper use of item only what it is designed to do

*Regular maintenance and cleaning

In areas of high content of salt air, pollution & moisture require more frequent cleaning.

Claim management:

To make a warranty claim, customers can either contact the retailer where the purchase was made or Furniture Solutions on contact details on page one. Proof of purchase will be required before proceeding with any claim. In the case of product defects providing photos may be able to speed up processing of the claim. If missing parts please refer to assembly instructions for identification of said part and contact either of the above.

“Our goods come with guarantees that cannot be excluded under the Australian Consumer Law. You are entitled to a replacement or refund for a major failure and for compensation for any other reasonably foreseeable loss or damage. You are also entitled to have the goods repaired or replaced if the goods fail to be of acceptable quality and the failure does not amount to a major failure”.

MADE IN CHINA

Imported by Furniture Solutions (Aust) Pty Ltd
10-16 Daist Street Revesby 2212