



## INSTRUCTION MANUAL

### HENRI

### RECLINER CHAIR & FOOTSTOOL

CODE: 19HEN

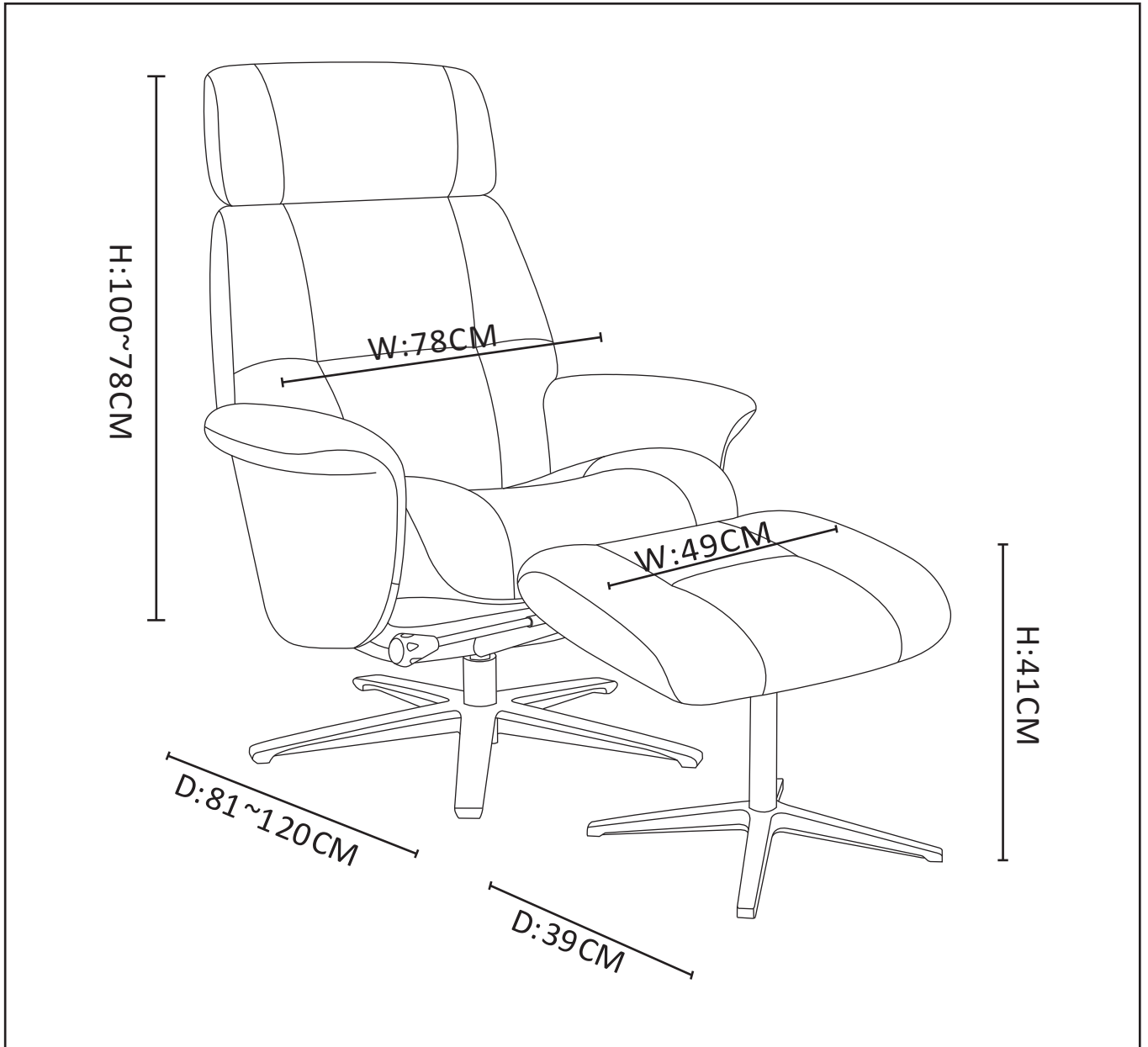

Imported by Furniture Solutions (Aust) Pty Ltd New South Wales, Australia.  
For any assistance with assembly or for missing parts please contact:  
Place of purchase or Furniture Solutions on below  
Customer Service (Australia) Phone-1300 794 188  
Email-customer-service@furniture-solutions.com.au

## PRE-ASSEMBLY PREPARATION

**Avoid use of powered/battery drills.** Improper use of drills can irreversible damage to fittings.

### **Before you start:**

1. Choose a clean, level, spacious assembly area. Avoid hard surfaces that may damage the product
2. Take care when lifting. Product should be assembled as near as possible to the point of use
3. Ensure that you have all required contents for complete assembly
4. **Ensure to check all components for any damage before assembly.** Please report any damage found to below, if possible forward images of component to below
5. **Always read the assembly instructions carefully before beginning assembly.**
6. Keep all hardware parts and packaging out of reach of small children.
7. Do not over tighten the screws and bolts as this may damage the threads

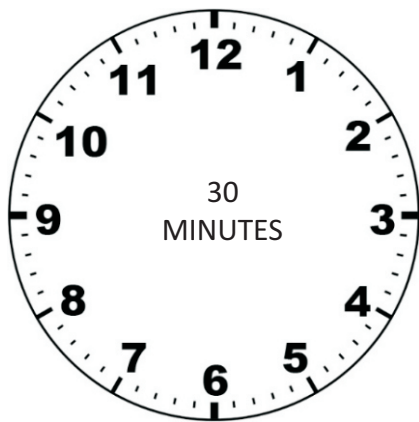

ALLOW TIME

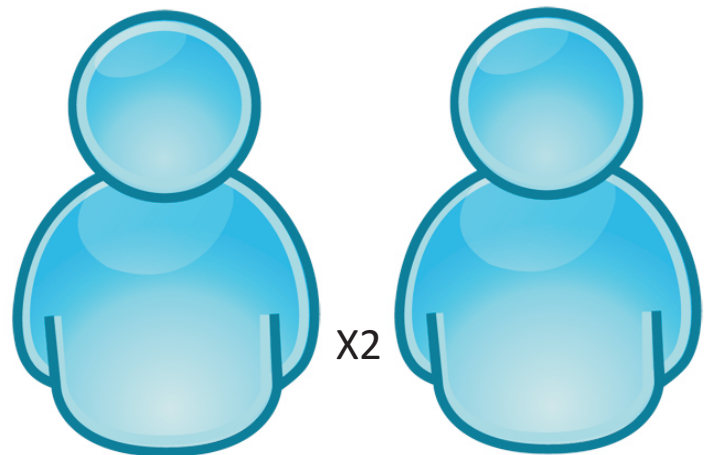

PEOPLE REQUIRED

For any assistance with assembly or for missing parts please contact:







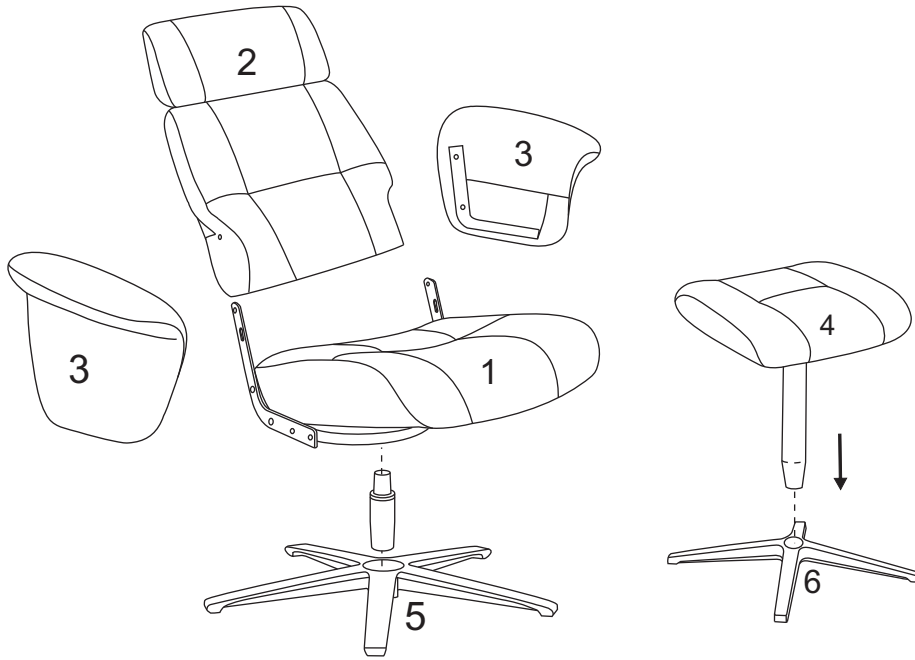

Place of purchase or

Furniture Solutions Customer Service (Australia) Phone - 1300 794 188

Email- [customerservice@furnituresolutions.com.au](mailto:customerservice@furnituresolutions.com.au)

# PARTS LIST

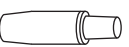
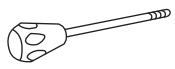
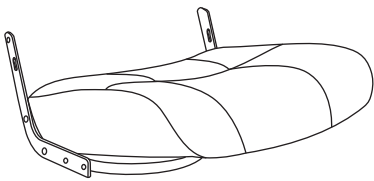
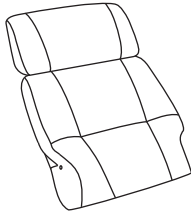
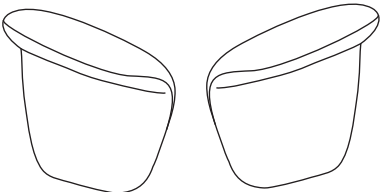
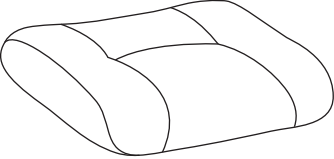
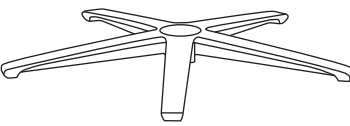

<b>A</b>	 M6X20	4PCS	<b>D</b>	 M8X35	3PCS	<b>G</b>	 6mm	1PC
<b>B</b>	 Footstool post	1PC	<b>E</b>	 M6X20	6PCS	<b>H</b>	 4mm	1PC
<b>C</b>	 Chair post	1PC	<b>F</b>	 Knob/Shaft	1PC			
1.Seat Cushion			2.Backrest Cushion			3.Armrest Pads		
								
4.Footstool Cushion			5.Chair Base			6.Footstool base		
								

# ASSEMBLY INSTRUCTIONS

Please prepare work area as instructed in page 2:

## To Assemble Footstool:

Identify required hardware before you start assembly. Note do not over tighten any bolts, tighten only until feels firm.

Take footstool cushion [4], place upside down as per diagram. Next take footstool stem [B] and align all 4 holes as indicated in diagram. Then take bolt [A] by hand and insert thru hole in stem into threaded hole of footstool cushion and turn 2-3 times to ensure thread on bolt has gripped threaded hole in cushion. Do not tighten yet. Repeat for other 3 bolts [A] until all bolts are seated correctly. Once all seated correctly take tool [H] and tighten all four (4) bolts until feels firm. DO NOT OVER TIGHTEN. Then position footstool base [6] on a firm level surface and insert stem into base as shown in diagram, you will need to ensure tube is inserted squarely, once you are satisfied all square, with caution sit on footstool top to add the pressure required to lock in stem and base together.

Move to Chair base Assembly next Page.

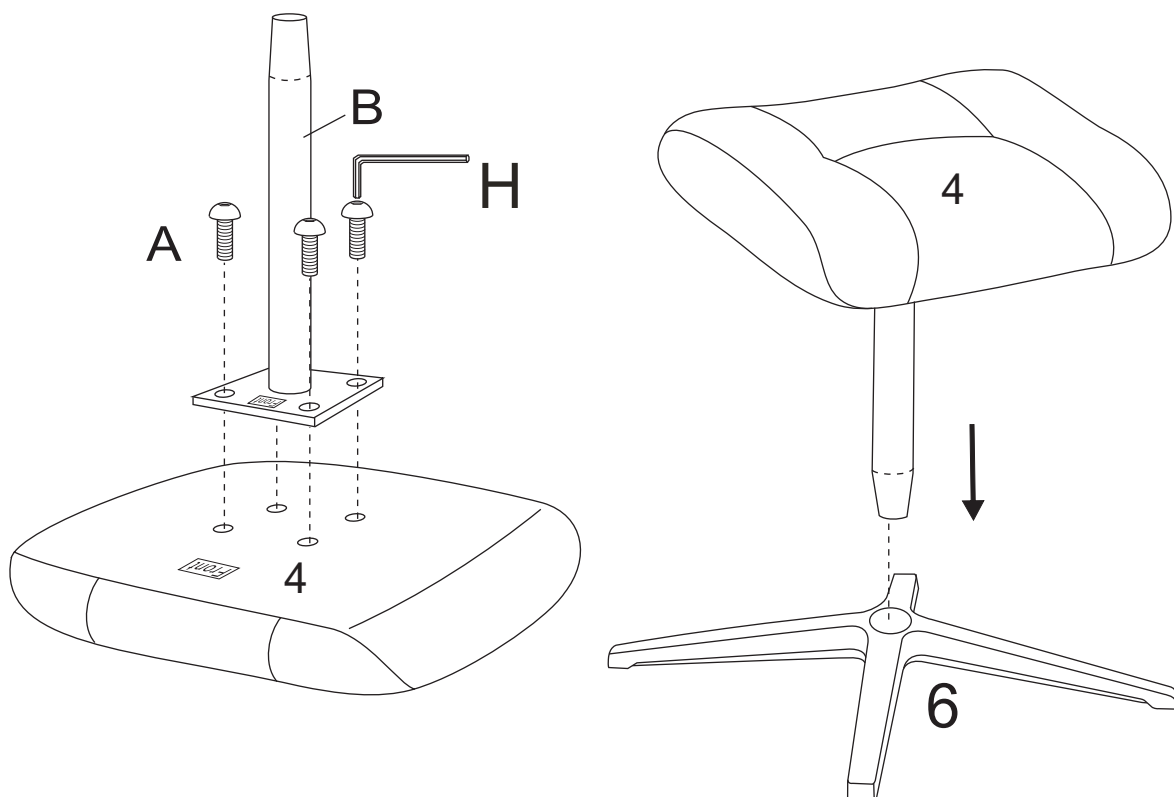

# ASSEMBLY INSTRUCTIONS

To Assemble Chair, chair base assembly

You will need the help of another person thru this stage.

As indicated on diagram place chair base [5] on a flat level surface. Take chair stem [C] insert thicker end into chair base, check that it is square. With help of another person pickup chair seat cushion and frame [1], locate hole in middle of frame under cushion, insert squarely onto chair and stem as indicated in diagram, check that it is fitted correctly should be no movement in lower frame. Move to backrest assembly

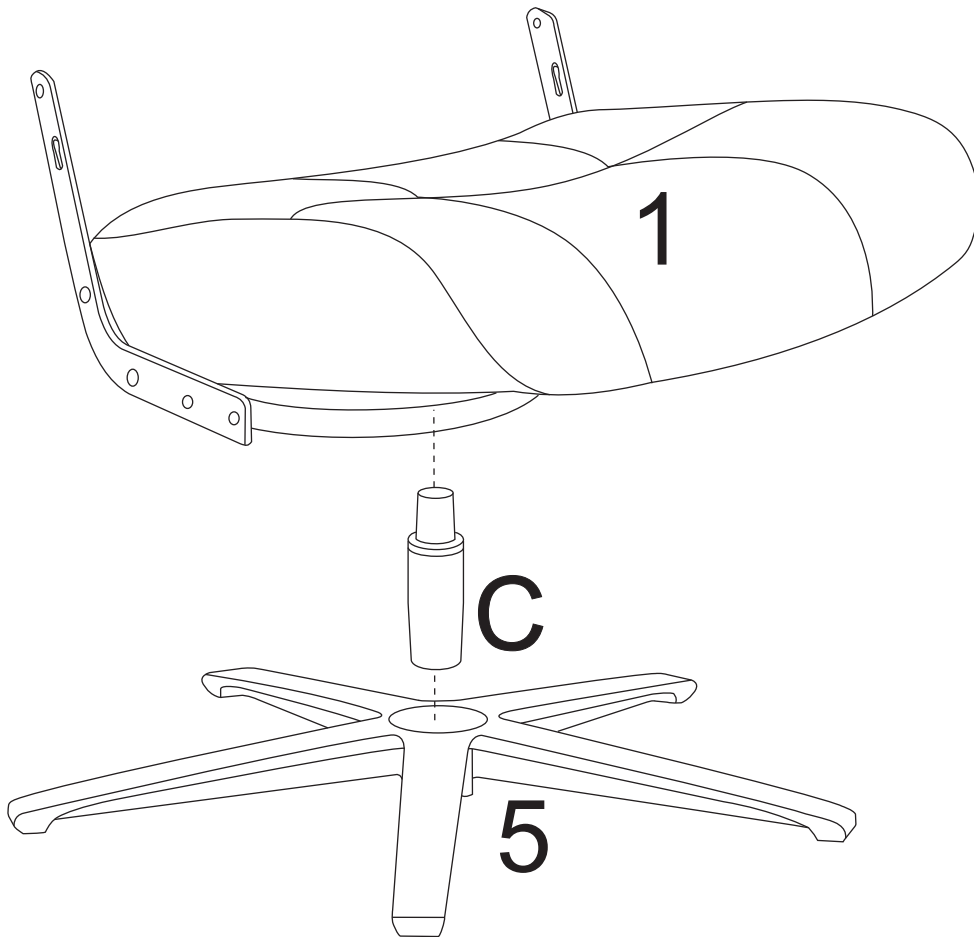

# ASSEMBLY INSTRUCTIONS

To Assemble Chair, Backrest assembly

You will need the help of another person thru this stage.

Next is to fit backrest [2] to seat cushion. You will note that seat cushion can move forward and backward, please position seat cushion so you have a clear view of threaded bolt hole in black frame at back of cushion, you may need to move leather to view holes. With the help of another person take backrest and align backrest with seat cushion as shown in diagram. Note on Right Hand Side Facing you will see a black painted pin extending from frame, please insert coordinating hole on backrest, next align threaded hole in seat cushion frame with hole in backrest on left hand facing side of chair, insert by hand bolt [D] turn 2- times to ensure tread is seated properly, please do not tighten as yet.

Note this bolt acts as a pivot once fully tighten do not over tighten once advice to tighten is instructed.

Next as per diagram you will need to fit 2 more bolts (pivots) higher up on backrest, align backrest cushion so that holes at top of chair frame match the threaded holes in backrest. Take bolt [D] insert thru hole in chair frame into threaded hole and by hand turn 2-3 times to seat thread correctly, once complete repeat for other side. Once both fitted take tool [G] and tighten all 3 bolts that are in backrest. Note all these bolts act as pivot and only require to be tightening until thread is not visible. Move to next page for arm pad assembly.

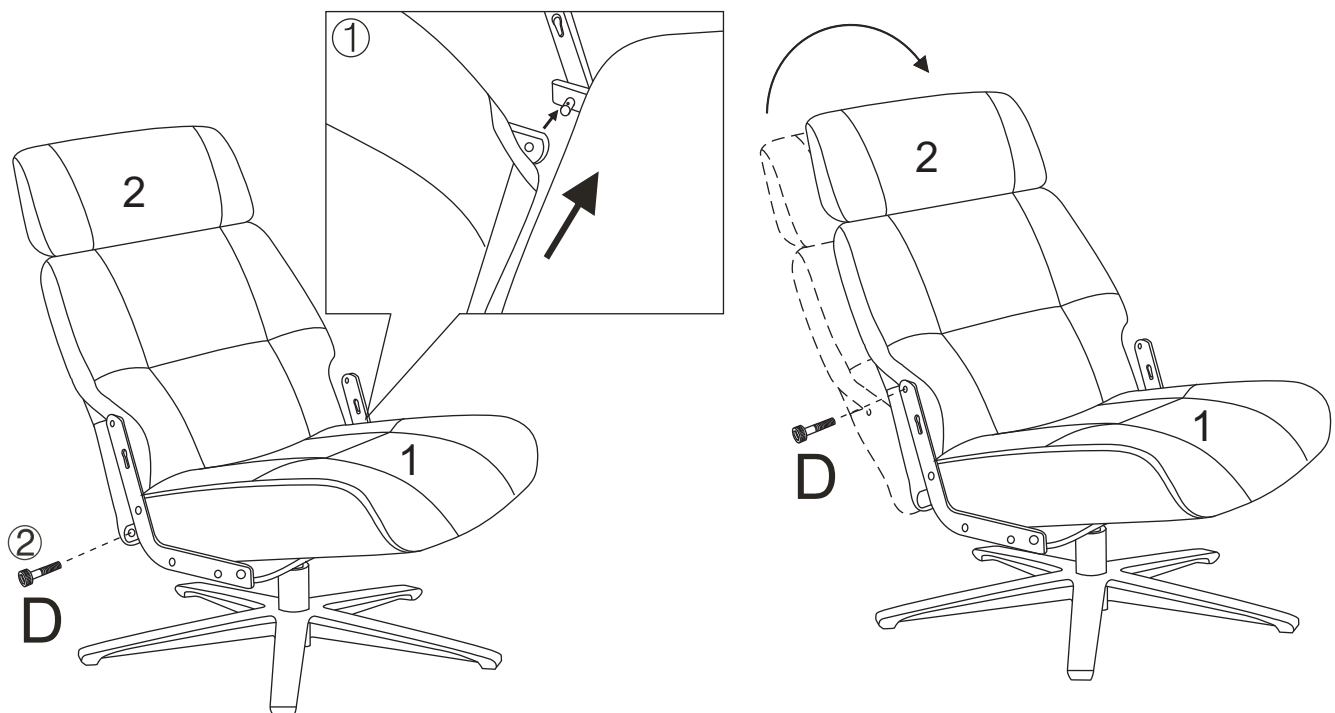

# ASSEMBLY INSTRUCTIONS

## To Assemble armrest pads:

To fit armrest pads [3] you will be required to pull backrest back to be as flat as possible. Please position armrest pad as per diagram, align holes in chair frame to threaded holes in armchair pads, insert bolt [E] into hole of frame and into threaded hole of arm pads, turn 2-3 times to seat thread correctly. Do not tighten yet. Repeat for other 2 bolts once all three (3) bolts are fitted, take tool [H] and tighten until feels firm. DO NOT OVER TIGHTEN. Repeat process for other arm. Move to fit locking arm.

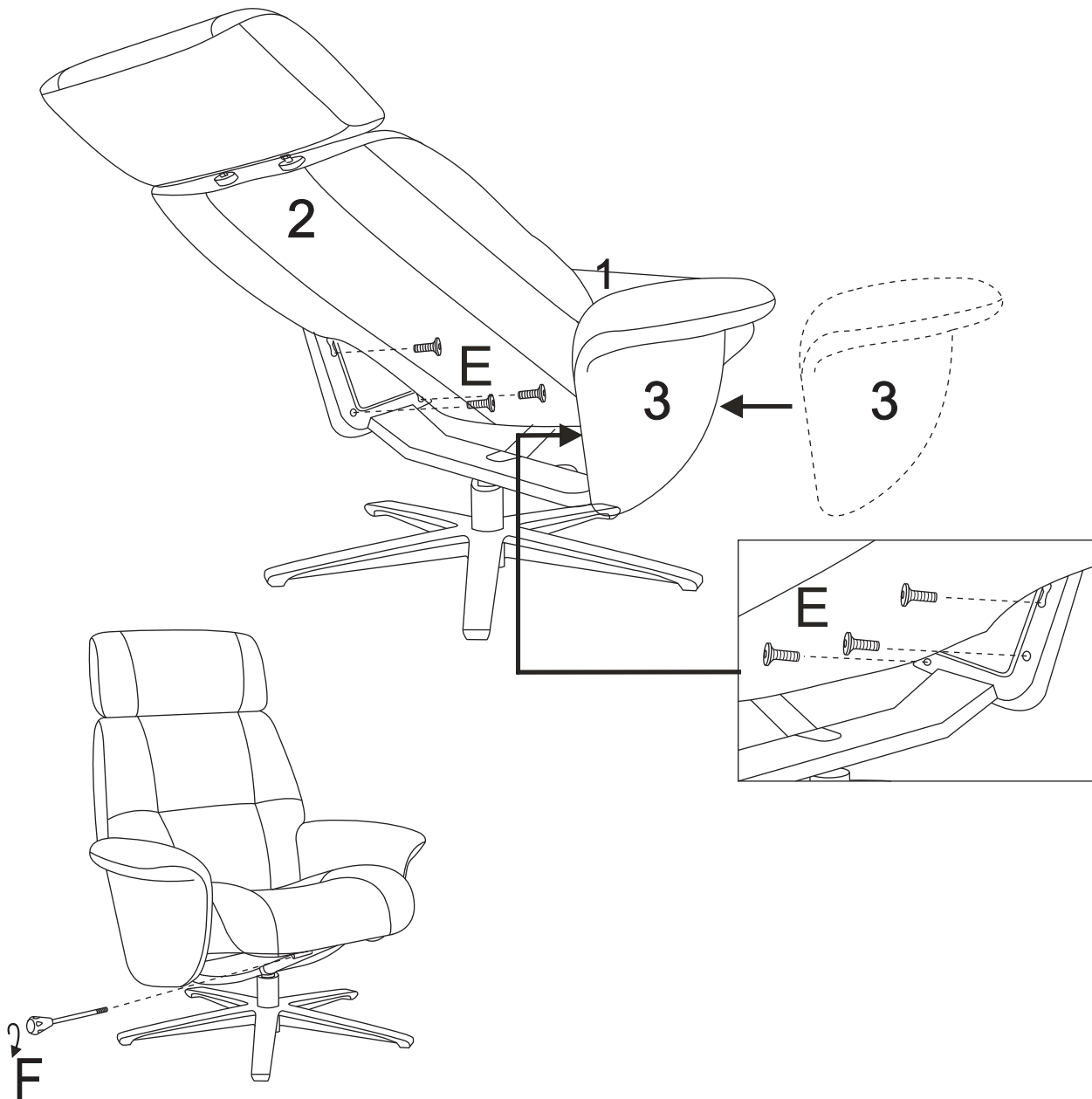

## To fit locking arm:

Please locate underneath seat cushion on black frame a threaded hole as per the diagram. Take locking arm [F] insert threaded end into thread of chair frame and turn 2-3 times to seat in thread properly. Note this locking arm acts as a brake system for reclining action on chair, please see operating instruction in coming pages. Assembly Complete please see operating instruction before you use.

# ASSEMBLY IS COMPLETE





## FEATURE'S AND OPERATING OF RECLINER

### *Operation of Recliner:*

#### **Locking of backrest in desired position.**

The locking mechanism is design for variable recline positions, so you can find the preferred angle for siting.

Turn knob (locking arm) clockwise to lock and anti clockwise to loosen.

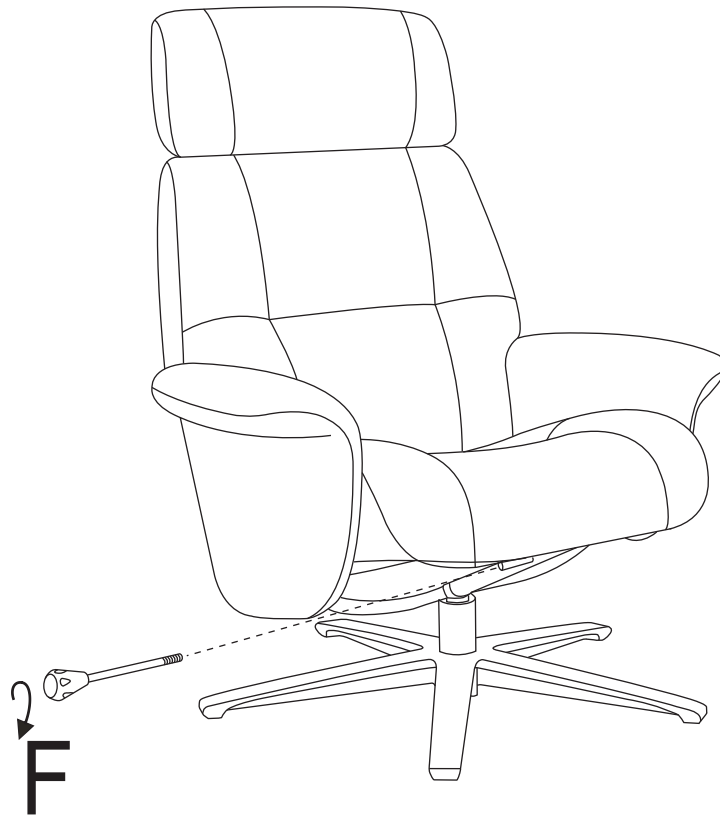

### **FEATURE:**

#### **Swivel base.**

Complete 360 degree turning circle.

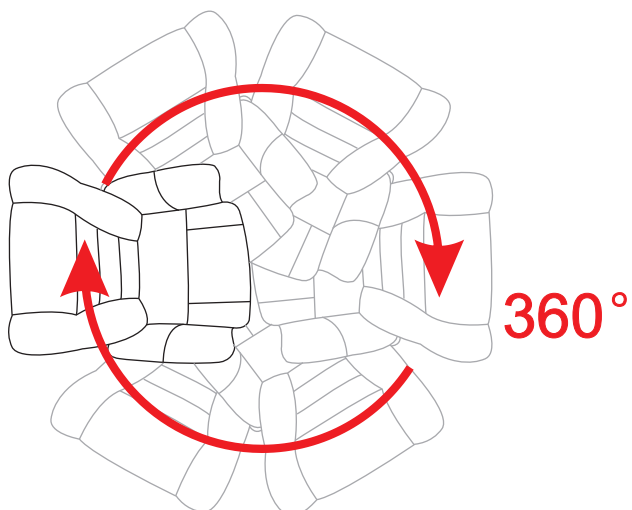

# FEATURE'S AND OPERATING OF RECLINER

## **Feature of Recliner:**

### **Adjustment of head rest:**

Internal Adjustable head rest for variable positions.

Please review diagrams below before operating headrest function.



To Adjust Headrest: Place both hands over shoulder as shown in diagram. Gently pull with both hands to desired position.



**DO NOT PULL FROM SIDE:** May cause damage to seams.



To return headrest back: push on both sides or use forearm to evenly move headrest back.

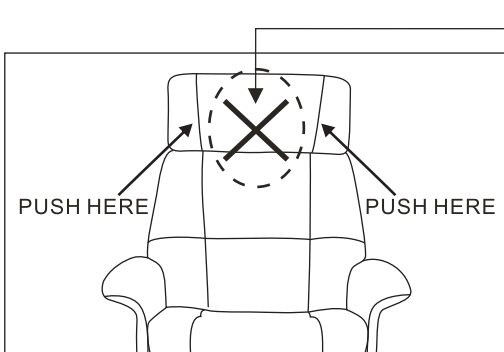

### **CAUTION**

Always apply pressure to edge of Frame never in middle of headrest as may cause damage to filling.

## CARE AND MAINTENANCE

Varieties of materials are used in construction of “Recliner” furniture range, Such as Stainless Steel; Nickel plated steel; Chrome plated steel; Powder coated steel; Timber, Leather, PU synthetic fabric & a variety fabrics.

All will require some form of maintenance to extend the life of finishes and general appearance. Please see below instruction unique to your chosen model.

### ***Henri Recliner Chair and footstool***

Covering :Cowhide Leather

Base : Aluminium Alloy

### ***Leather Covering;***

Keep dust free at all times.

Regular use a damp soft clean cloth and wipe down leather.

Pay special attention to areas where skin touches leather. IE : Armrest Pads, Headrest, front section of chair and footrest tops.

Please clean up spills immediately. Ensure to dry properly before use.

### ***Periodic Leather Cleaning;***

Every 3-4 months you need to give leather a good clean to remove excess body oils.

Please purchase a propriety leather cleaner and follow all directions indicated on packaging.

You could also purchase a leather conditioner/protector to complement the leather after a good clean.

Frequency of periodic cleaning can vary due to colour of leather, use and environment.

A chair used 2 hours a day will require less cleaning than a chair used 8 hours a day.

Areas of high humidity will require more cleaning than areas of low humidity.

### ***Professional Cleaning;***

Even the most diligent house keeper cannot always prevent leather from aging or looking tired.

We recommend you use the services of a reputable leather cleaning service when your cleaning does not appear to make a difference in appearance.

### ***Things to know about leather;***

The surface of leather can be affected by chemicals used in hair spray, gel, mousse, perfume, deodorants, some medications, alcohol and dye transference from clothing. Please factor this into your cleaning regime.

### ***Aluminium Alloy Base;***

Please remove dust and grit on metal as required.

When grease stains and tarnish begin to appear, you'll need to clean off your plating. By washing first with warm water, using a metal cleaner for persistent blemishes, and then polishing, you will keep your nickel plating strong and lustrous for years to come.

## SAFETY WARNINGS AND ADVICE

### *Notices and Advice*

Please be advised that products are limited in design for residential use only and are not suitable for commercial use.

Please be advised that materials used in your furniture are not impervious to neglect, acts of god, abuse, alcohol spills, improper use of chemicals such as bleach or any solvent based products.

Please be advised that heat sources such as direct sunlight, log fires, heaters and air conditioners can have adverse affects on your furniture.

Please be advised that fitting, bolts, nuts and or screws should be checked periodically to ensure they have not loosened over time. Remember do not overtighten.

Please be advised coverings are not animal proof. Claws can scratch covering & saliva is acidic and can damage finish of covering.

#### DO NOT

- Place in direct sunlight.
- Place in close proximity to open flame or heaters.
- Place in direct line of air conditioning ducting.
- Leave spills or food on sofa clean off immediately
- Pull loose thread, cut them instead.
- Sit or lean on arms
- Stand on chair

### *Safety warnings*

- DO NOT:
  - drop, drag always with the help of another person lift and place, to avoid damage to floor surface & base of recliner chair.
  - Sit on arms or back when upright, this could damage internal mechanism.
  - Fold mechanism with linen or cushions on sofa.
  - Pull loose thread, cut them instead.
  - Jump, flop or stand on sofa.
  - Always release both glide handles before you attempt to move into upright position.
  - Ensure swivel mechanism on chair base is clear of loose threads, long carpet fibre's or simular items

## WARRANTY DETAIL

### 2 Year Warranty

A two (2) year warranty applies to product against any defects associated with faulty workmanship for a period of (2) year from date of purchase.

Furniture Solutions accepts no responsibility for defects caused by incorrect assembly, mishandling, acts of god, general wear & tear including fading, creasing of covering, aging of foam and fibre filling IE Height reduce over time, stains from spills, chipping/scratching, exposure to extreme heat/cold, mould/mildew, hardware corrosion, misuse of the products & defects caused by failure in duty of care for the product in accordance with the care instructions. Warranty is based on normal household use and not for commercial use. Warranty only extends to original purchaser and is not transferable, except when given as a gift.

### Notice:

While every effort is made to use quality materials our products are limited in design for domestic use only & are not suitable for commercial use.

Care should be taken not to place product near heat sources.

### Duty of care:

While every attempt is made to supply product using quality components there is always a need from consumer to help ensure long life of use for product. Instruction manuals are designed with the nature of materials used in construction of the product.

\*Proper use of item only what it is designed to do

\*Regular maintenance and cleaning

In areas of high content of salt air, pollution & moisture require more frequent cleaning.

### Claim management:

To make a warranty claim, customers can either contact the retailer where the purchase was made or Furniture Solutions on contact details on page one. Proof of purchase will be required before proceeding with any claim. In the case of product defects providing photos may be able to speed up processing of the claim. If missing parts please refer to assembly instructions for identification of said part and contact either of the above.

“Our goods come with guarantees that cannot be excluded under the Australian Consumer Law. You are entitled to a replacement or refund for a major failure and for compensation for any other reasonably foreseeable loss or damage. You are also entitled to have the goods repaired or replaced if the goods fail to be of acceptable quality and the failure does not amount to a major failure”.